



SCOTTSDALE

CONSTRUCTION SYSTEMS



INSTALLATION MANUAL

GLOBAL HEADQUARTERS

Unit 4, 5 Henry Street,
Loganholme, Queensland 4129
Australia
P: +61 1300 671 345

MANUFACTURING FACILITY

17 Cadbury Road,
Onekawa, Napier 4110
New Zealand
P: +64 6 843 6276



sales@scottsdalesteelframes.com
www.scottsdalesteelframes.com



Chapter 1	Tools & Equipment	3
Chapter 2	Handling & Storage	5
Chapter 3	Standing & Connecting Walls	7
Chapter 4	Ceiling	13
Chapter 5	Ceiling Supports	19
Chapter 6	Roof Panel	23
Chapter 6a	Soffits & Fascia	31
Chapter 7	Roof Trusses	35
Chapter 8	Hybrid Roof	45
Chapter 9	Floors	49
Chapter 10	Miscellaneous	55
Chapter 11	Reading ScotLayout	59
Glossary	Steel Framing Terminology	65

General Notes & Information

It is important to develop and maintain a safety plan before commencing any construction. This should include, but is not limited to, all safety equipment which may be required.

Scottsdale Construction Systems has developed this installation manual to assist first time or novice steel frame users with a reference guide on how to install the ScotPanel and ScotTruss systems.

It is important that all work carried out while using this guide meets local building authority regulations and safety plans.

This Installation manual illustrates simple and commonly accepted building practices, as used by existing customers around the world. It is intended that processes shown within this manual are a guide only, and the installer should use discretion when circumstances do not match the criteria laid out within portrayed examples.

Disclaimer

Scottsdale Construction Systems Ltd (SCS) makes no representations or warranties of any kind, express or implied, nor accepts any liability whatsoever about the completeness, accuracy, reliability, suitability, compliance or lawfulness of, including but not limited to, any Design work, Technical drawings, Engineering Data or any information compiled by SCS. This includes any design work supplied to, or done on a customer's behalf.

It is the Customer's responsibility to ensure the design is accurate and is in accordance with the building plans and that the final design meets local building codes, and any other statutory requirements. Similarly, it is the Customer's responsibility to ensure all Technical or Engineering data supplied by SCS meets local statutory requirements.

In no event will SCS be liable for any loss or damage, including without limitation, indirect or consequential loss or damage, or any loss or damage whatsoever arising from any errors or omissions, but any dispute shall be construed under the laws of New Zealand whose Courts shall have exclusive jurisdiction in respect thereof.





Power Tools

- Rotary Hammer Drill
- Cordless Drills with Torque Settings
- Cordless Impact Driver
- Right Angled Drill
- Concrete Nailer
- Power Drill for Flooring



Tool Accessories

- 7.9mm (5/16") Hexagonal Drivers
- Short Driver 50mm (2")
- Long Driver 150mm (6")
- Twin Head Magnetic Phillips No: 2 Short Driver
- Twin Head Magnetic Phillips No: 2 Long Driver
- Double Ended Drill Bit 4.9mm
- 10 /12mm Tungsten Carbide Concrete Drill Bits
- Cone Drill 6mm - 30mm
- Hammer
- Square
- Step Ladder



Hand Tools

- Double Action Tin Snips (left and right hand)
- 1.8m Long Spirit Level
- Marker Pen (fine tip)
- String Line
- Adjustable C Clamps
- Tape Measure
- Magnetic Grab Stick
- Socket Set
- Socket Set for hold downs
- Hand Riveter
- Stanley Knife
- Pinch Bar/Crow Bar









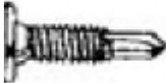

Personal Protective Equipment

Personal Protective Equipment
Please refer to the Health and Safety Regulations of the area where construction is being carried out

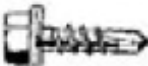
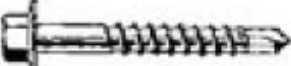

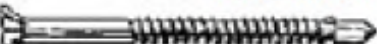
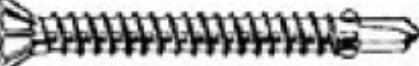
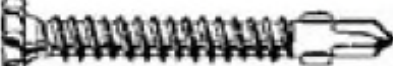

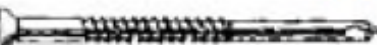
Fasteners

Description	Uses
 <p>10-16x16mm Tek</p>	Flush fixing screw where flush surface finish is required, e.g. Plasterboard corner angles.
 <p>10-16x16mm Tek</p>	General fixing screw. Uses: wall connectors, roof battens etc.
 <p>12-14x20mm Tek</p>	Structural fixing screw, tiles roof truss fixing, girder/truss heel bracket fixing, roof battens.
 <p>14-10x20mm Tek</p>	Structural fixing screw low wind area. Sheet roof truss fixing, rafter beam fixing and high load sheet connections.
 <p>12-14x45mm Tek</p>	Fixing wall bottom plate to steel joints.
 <p>12-24x32mm Hex series 500</p>	Used for fixing steel brackets or joists to heavy gauge beams up to 12mm thickness.
 <p>10-24x75mm CSK Wing Tek</p>	For fixing timber batten or timber to steel. Timber thickness range 25-30mm.
 <p>10-16x45mm CSK Tek</p>	Timber floor to steel joists fixing. General timber to steel. Timber thickness range 30mm.
 <p>8-18x35mm SEH Wing Tek</p>	Used on Hardiplank. Weathertex and assorted timber claddings to steel stud work. (Use stainless steel for cedar).
 <p>6-20x50mm CSK Wing Tek</p>	Architraves, reveals and skirtings. General finishing and fixing timber screw.
 <p>6-20x65mm CSK Tek</p>	Architraves, reveals and skirtings. General finishing and fixing timber screw.
 <p>6-18x30mm Bugle Needle Pt</p>	Plasterboard fixing to ceiling battens.
 <p>6-20x25mm Bugle Drill Pt.</p>	Plasterboard fixing to wall frame studs.



On Site Handling

Lifting, loading and transportation of steel frames should be accomplished with sufficient care to prevent damage. Frames must be fully supported in either horizontal or vertical planes when being transported to prevent buckling or crushing. Care must also be taken when tying down and lifting wall frames.

When a crane is used to unload frames, suitable lifting methods are required to prevent damage at the lifting points.

Sling trusses from the chord and web points. Sling wall frames from top plate and stud connections. Slings should be located at equal distances from the centre lines of trusses and walls. Approximately one third to one half the length apart. The angle between the sling legs should be 60 degrees or less and where truss spans are greater than 9000mm, a spreader bar or strong back should be used.

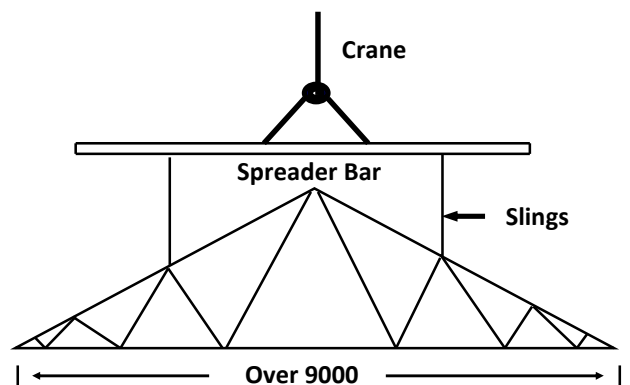
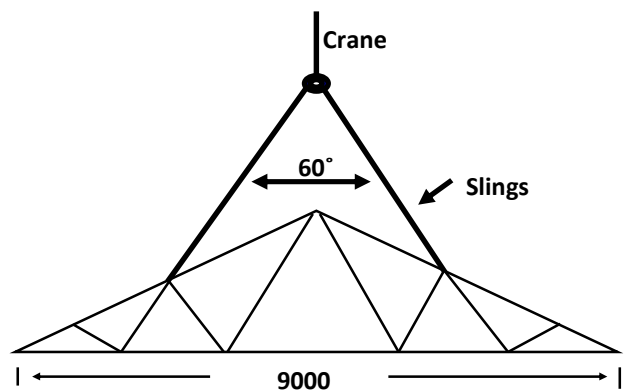
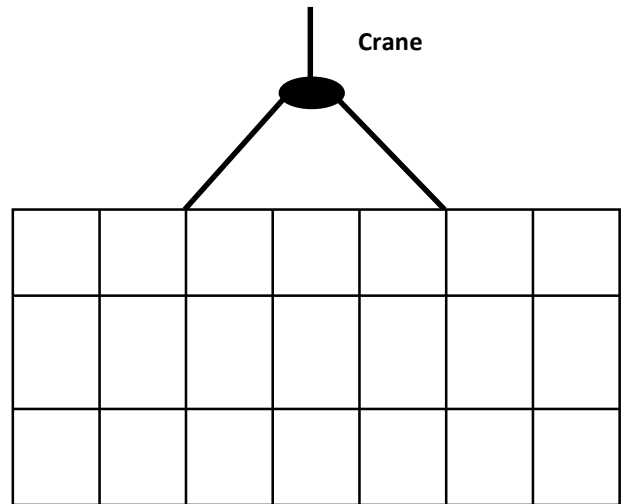

All frames should be inspected on arrival to site for damage. Any damaged parts must be reported immediately to the supplier so they can be rectified. Any site repairs without prior approval from the suppliers may affect the structural integrity.



Stacking Steel Wall Frames and Trusses

Steel wall frames and trusses and other associated ancillaries should be kept off the ground. This can be achieved by stacking the frames on blocks, spacing them 1000mm—1500mm apart ensuring the blocks are positioned where studs join the perimeter members.

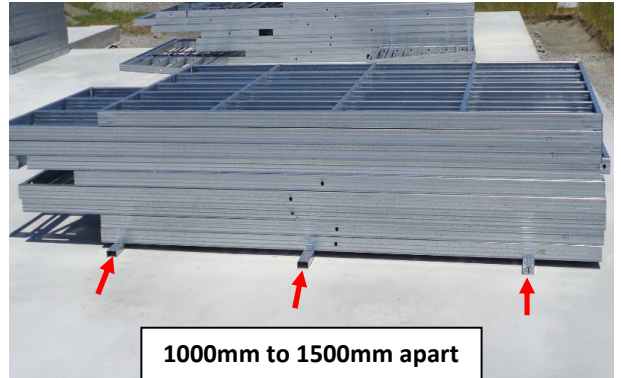

Frames need to be stacked neatly to prevent buckling. A good point to remember is to stack frames on a flat surface with the orientation hole in the bottom plate on the left hand side of the stack. This will allow for easy identification and frame orientation when standing frames which will be discussed later on in this manual.

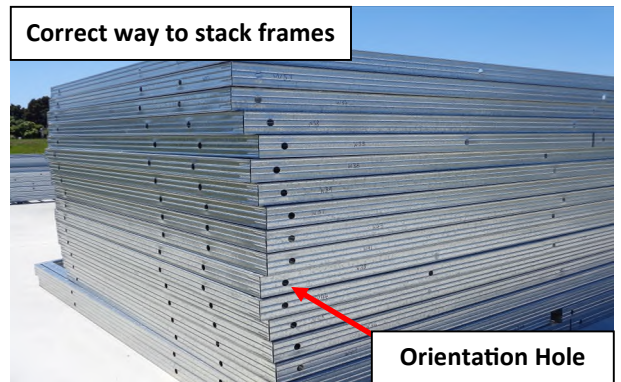
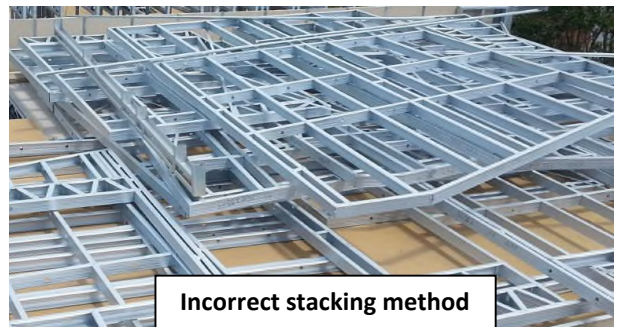



Frame Labels and Orientation

All wall frames come with an ORIENTATION HOLE. This is indicated by a SERVICE HOLE punched into the Bottom Plate 100mm from one end. This is displayed on ScotLayout by a dot at one end of the frame. The frame label is usually written on the bottom plate near the orientation hole, but this may differ between fabricators.

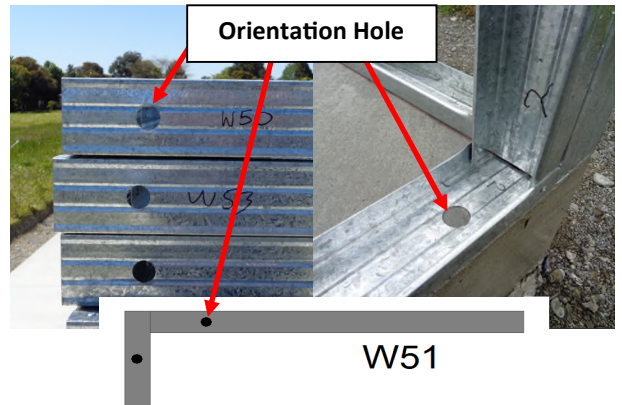

Attaching Strap Bracing

If Strap Bracing is not attached by the frame fabricator then it's best to attach before standing the frames. Locate the positions on the frame where strap bracing is required. Make sure the frame is square before attaching the strapping. Ensure the correct number of screws are used at each end of each strap.



Bottom Plate Strap Bracing Fixing as Per Layout



Top Plate Strap Bracing Fixing as per layout

Tensioners should be left loose until the frames are fixed down. They can then be tightened to help plumb the frame. Hold Down Bolts with "L" brackets should be used at each **END** stud of all strap braces or where specified on erection layouts.



"L" Bracket Brace Hold Down



Strap Brace Tensioner





Where to Start—Slab Markout

Before standing the first frames, it is a good idea to use a chalk line and mark two lines at right angles to each other across the centre of the foundation then measure from these lines the required distance to position the exterior walls. This is done to ensure the framing will be laid out square on the foundation and wont be influenced by the edge of the foundation which could have small variations (eg. the concrete edge could have a curve in it)

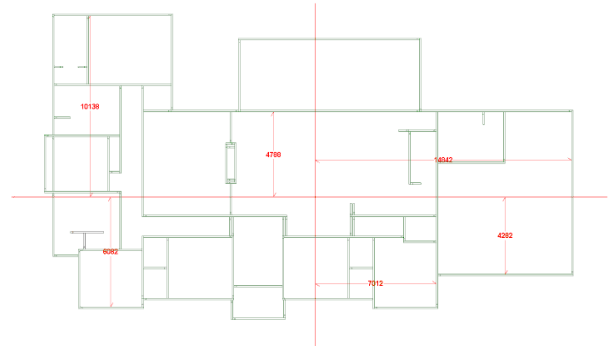

Wall Frames should be positioned around the foundation to minimise the distance frames are carried prior to standing. Consult the supplied frame layout when the frames are delivered so this can be done with the delivery crane or similar. Position frames around the outside of the foundation in the correct orientation to assist with the speed of erection.



Lay frames around the foundation prior to standing walls

Standing Frames

When standing frames to an upright position it's best to use two people.

Pick the frame up at each end and rotate so the orientation hole is at the bottom. Nogs should also have the open side of the profile facing down.

Two people can also lay the frame on the ground and pick up the top plate and lift only the top plate up and walk inwards until the frame is vertical. Long frames need special care and should be supported in the centre and around openings otherwise the top/bottom plate could bend. Carrying the frame vertically can alleviate this problem.

Refer to the wall layout to identify the location of the orientation hole.

DPC should be used between all bottom plates and concrete surfaces. Refer to the following page for further details.





Attaching DPC

DPC can be attached to the bottom of the Wall Frames prior to standing.

DPC should be placed under the bottom plate of steel framing walls to prevent a chemical reaction between cement and the steel galvanising. Because of this DPC should be slightly wider than the framing it is protecting.

The image to the right shows DPC attached to the bottom plate with wafer head Tek screws. Ensure the screw is located in the centre of the web. The screw will fit neatly between the steel web and the concrete. Screw spacing should only be placed where they are required to hold the DPC securely until the frames are standing.

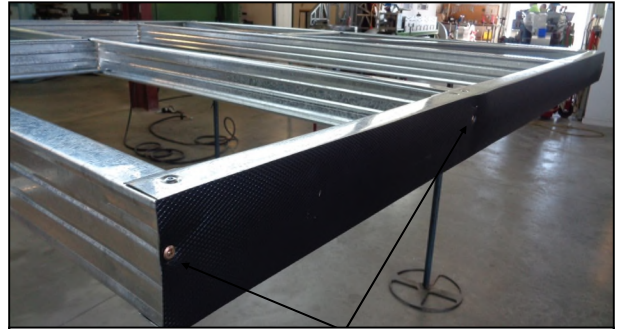

Place screws where required to hold DPC securely

DPC can also be glued onto the steel bottom plate. Most spray on adhesives will adhere to steel. Follow the instruction on the can to achieve results specific to adhesive type.

Some DPC manufacturers produce a product that has an adhesive backing already applied so it can stick to the steel.



Gluing DPC to the Bottom Plate

DPC can also be nailed directly to the concrete with a powder actuated fastener after the slab has been marked out with a chalk line.





Standing Walls

When standing the walls you should always begin in a corner using two frames. This allows one wall to hold up another. Ensure that you do not close in the exterior walls until all of the interior walls are in place. Closing in each room as you move across the floor will provide a stable structure to work away from.



Connecting Frames

When standing frames, one screw in the top and one screw at the bottom will be sufficient until all frames are standing.

Connecting frames should be done at maximum of 1350mm spacing's up the connecting studs. Use two screws at each horizontal member behind the connecting stud.

Screws can be added from either side if it is difficult to get the screws in from one particular side.

Once the frames are connected, ensure they are positioned on the floor correctly, then fix down to the floor with the required method.

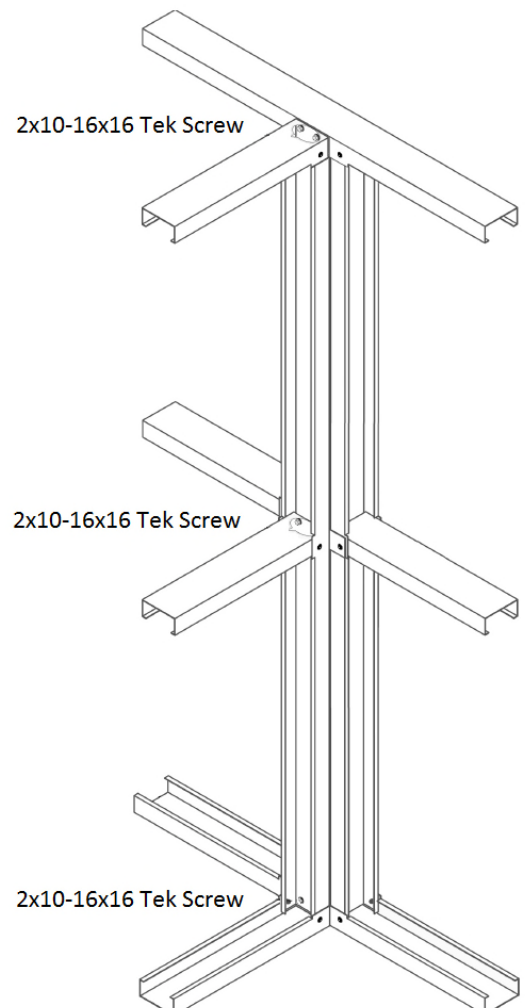



Temporary Bracing

Frames should be braced laterally to prevent the frame falling over.

“C” section lengths can be used to achieve this by adding small cuts to the flanges and bending them to suit before fixing them to the foundation.

Temporary bracing should be applied to any walls that are not supported by internal walls.

Ensure the brace angle is between 40° and 60°



Squaring and Straightening

Wall framing should be stood true and plumb, and in most cases at right angles to one another.

To ensure long walls are straight, a string line can be used to ensure the walls are straight. Place a block between the string and the framing at each end and measure at points along the frame to check for straightness. This should be done at the bottom plate prior to fixing down to the floor, and to the top plate when adding temporary bracing before the roof structure is added.



Hold Downs

Fixings to hold the frame down come in different forms. Some of these include a Concrete Nail and Washer, Expansion Bolt and Washer, Expansion Bolt and “L” Bracket, Concrete Screw and Washer, and Concrete Screw and “L” Bracket.



Hold down bolts are typically required at either side of window and door openings. Washer or “L” Bracket requirements are specific to each job.

Refer to the framing layout for the hold down type to be used.

Concrete nail and washer are typically used for Internal walls, and in some cases exterior walls (depends upon wind zone and uplift) and the spacing's should be set by your engineer.





Plumb and Level Frames

As you are erecting frames it is best practice to apply some "C" section lumber for bracing the framing and to keep it square.

Once frames are fixed down, the strap bracing can be tensioned to achieve plumb frames.

Perpendicular temporary bracing can also be applied to ensure the centre of walls are plumb. (refer to next page)

If the flooring has bumps or waves in it, it is best to pack the low spots to ensure the top and bottom plates are level along the length of the frame. This can be done by slightly lifting the frame in the hollow and putting a packing material under the bottom plate (Horse Shoe Shim or DPC is very common) until it is level.

Cutting Doorways

In most cases when the bottom plate is required to be cut out for a doorway or a window at floor level, a notch can be provided by the software detailer to allow the plate to be cut out easily.

The installer will need to cut with some hand snips the flange of the bottom plate approximately 30mm from the opening stud. Once cut, the piece remaining on the frame should be bent around the stud and fixed in place with at least one wafer head screw.

If a notch has not been provided, the same result can be achieved with some more work.

Cut the four flanges on a 45degree angle back towards the bottom of the opening stud. Bend these triangle pieces around the stud and screw off. The point can be cut off these triangles to make this safer. Once this is done cut the centre of the plate being removed any way you feel like. Then bend the piece to be removed up and down until it breaks off.

Door ways can also be cut out with an angle grinder. If you choose this method, spray on galvanising paint should be applied to any cut made with the grinder to protect the steel from corrosion.





After bracing has been applied, the ceiling panels can be placed into position starting at any corner of the structure.

When erecting ceiling panels, the first thing to do is become familiar with the ScotLayout supplied by the manufacturer.

There are no orientation holes in ceiling panels so the only way to recognize the frame direction is by the arrow direction of the rafter/joist or by any special nogs that have been put into the frame as per example C.42 in the adjacent image.

After reading the ScotLayout, place the panels around the building in the area in which they are to be located.

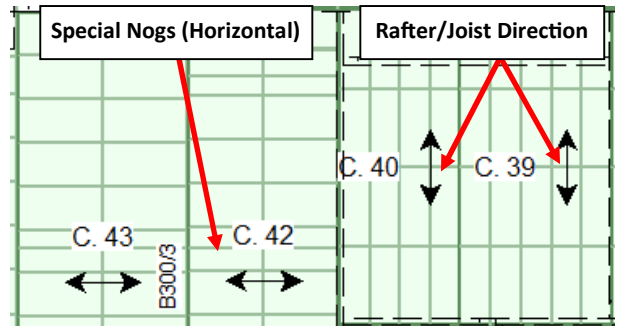

Before any ceiling panels can be laid on top of the wall framing, the whole building needs to be braced to hold the walls straight and plumb. This is to prevent the walls from moving when ceiling panels are moved into their final position. Refer to the previous chapter for details how to do this.

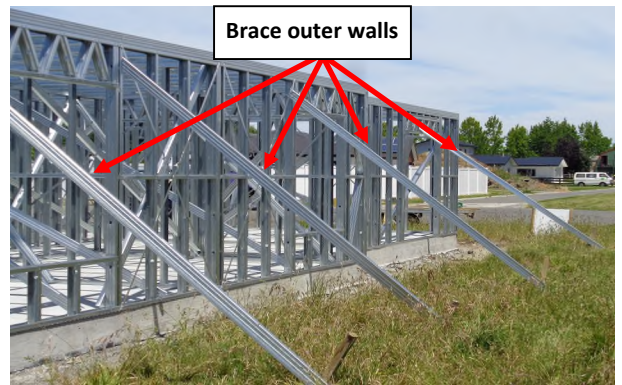

When positioning the ceiling panels, the outer perimeter of the ceiling panel needs to be flush with the outer edge of the wall frame. At this time the ceiling frame should only be screwed down with minimal screws to minimise movement when working on top of the ceiling panels. 2 Screws in each corner and one at midpoint between each corner is recommended.

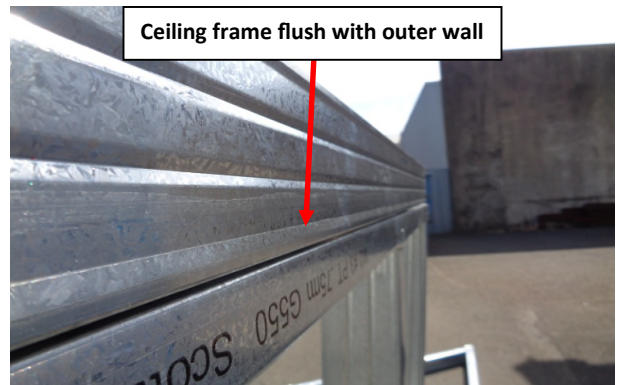

Once this has been accomplished, move onto the next panel, moving around the outer perimeter of the building until you meet up to the first ceiling panel. If the ceiling panel is supported by trusses or a support frame, temporary props need to be used until the trusses are installed. Temporary props are also used when working with a B300's or B400's.





Ceiling Beams

When installing ceiling beams a gap will need to be created between the ceiling panels. To achieve this, place material of similar thickness to the ceiling beam plate between the two ceiling panels and clamp or temporarily screw.

After the gap has been formed, secure the ceiling frames by screwing around the perimeter elements. Props are placed mid span so the ceiling beam has something to rest on while also supporting the ceilings and keeping workers safe. Lengths of "C" section material can also be used to prevent plate from protruding past the edge of the ceiling when inserted.

Note: Ceiling beams can come in a variety of depths.

Scotsteel Design Software can allow for panel growth by making the panels slightly smaller than required to ensure they fit on site. As a result of this, gaps can start accumulating in the ceiling panels. These can be easily hidden when two ceilings join on top of a wall. If you find the gaps are getting excessive contact the designer to modify the "Edge Adjust" dimension for future projects.

If the accumulated gap cannot be hidden on top of a wall (as per the image on the right) then the gap needs to be filled with a packer and screwed off.

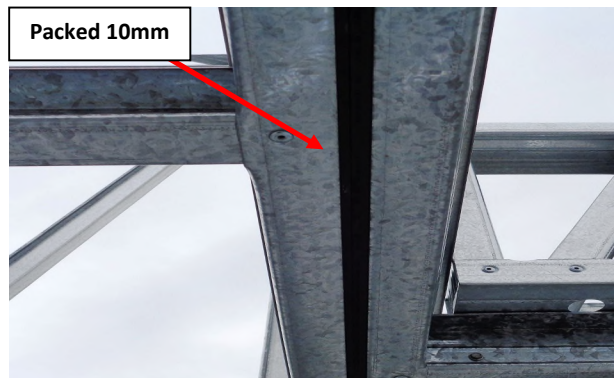
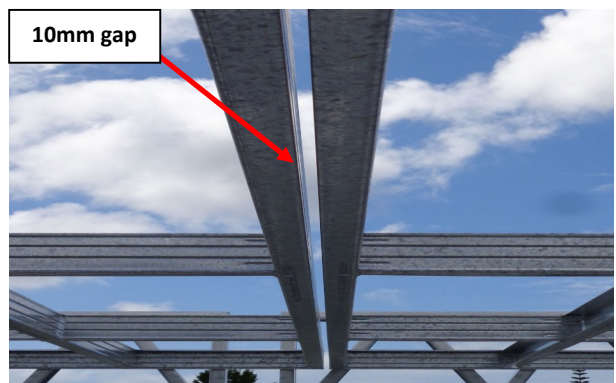
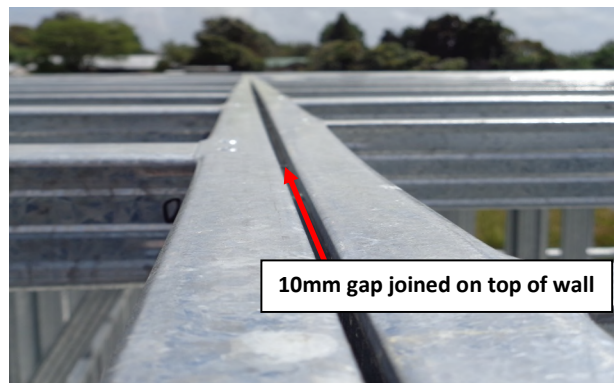
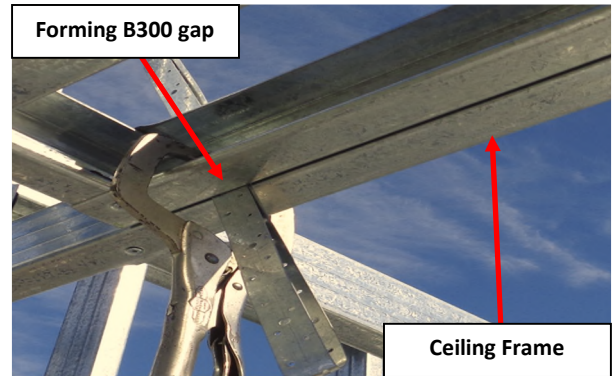



Fixing points for the outer perimeter of ceiling panels should be fixed by one Tek screw at 600mm spacing's or at each rafter.

Refer to the ceiling layout for additional fixings.

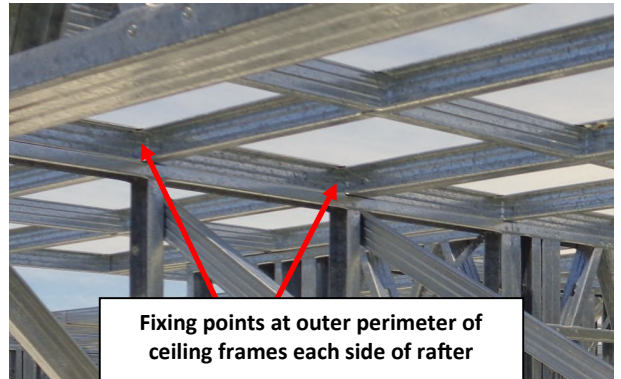

Ceiling fixing points to internal walls are fixed by screwing one Tek screw in each rafter that crosses the internal wall as shown here.

Refer to the ceiling layout for additional fixings.

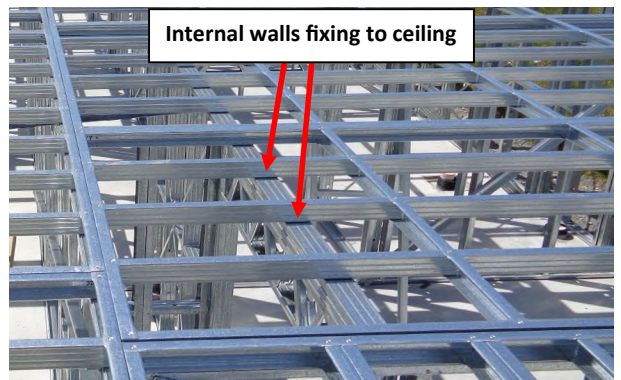

At this point, strap bracing (if required) can be fixed to the ceiling panels and tensioned. This is best done before the support frames are installed.

Refer to the ceiling layout for bracing locations and fixings.

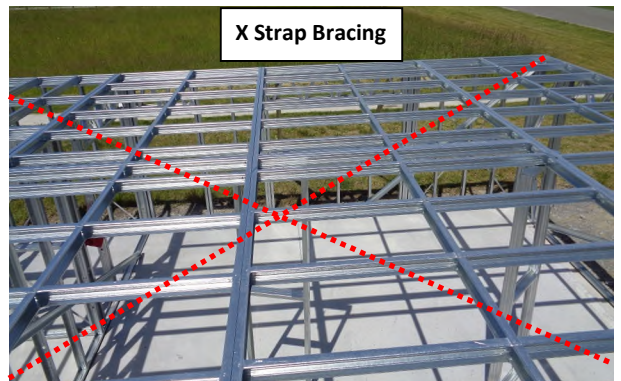



Constructing a Ceiling Beam

A Ceiling Beam is a plate of steel that is 300-500mm deep x the plate thickness the designer has specified eg: B300 x 1mm.

The 1mm is the gauge. 300 is the depth of the plate being used.

B400 and B500 is listed the same way, the difference being the depth of the plate is 400mm and 500mm deep.

Throughout this chapter a B300 is being used as the example.

Before fabricating a B300 refer to the ScotLayout as to where the B300 beams are located. In the adjacent image there are two B300 beams located between ceilings 42, 43, 44.

To calculate the length of the beams turn to the page in ScotLayout that has the corresponding measurements.

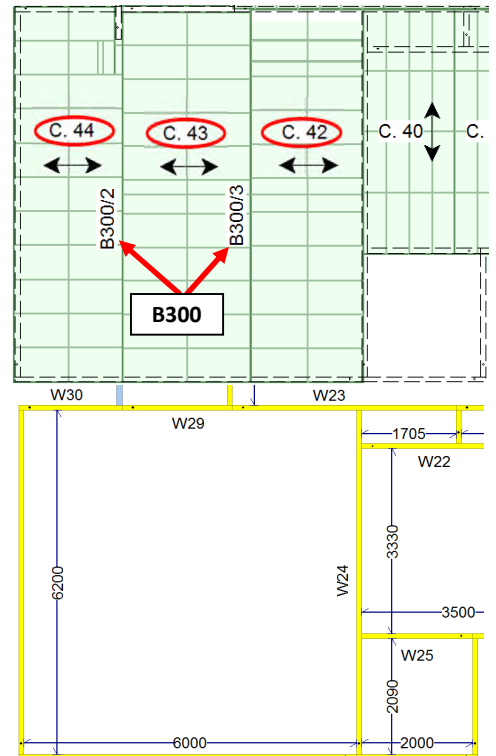

Find the area in ScotLayout where the B300's are shown and look for the measurement in the layout where the B300 is spanning. In this example the B300 is 6200mm plus the thickness of the walls.

Example: $6200 + 90 + 90 = 6380\text{mm}$. This is the overall length of the B300.

Some layouts will have this length specified for you.

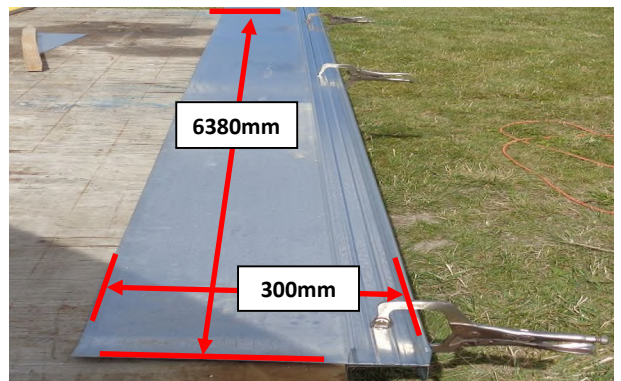

Cut the specified plate to the correct length then cut 2 x "C" Section's of the same length. Clamp the 2 x "C" Section's sandwiching the plate between them and fixing 2 x 10g-16x16 screws close to the flange edge of each "C" Section. Start 50mm from one end and work towards the other end fixing the Tek screws every 150mm, finishing 50mm from the end. This will form the top chord of the B300.

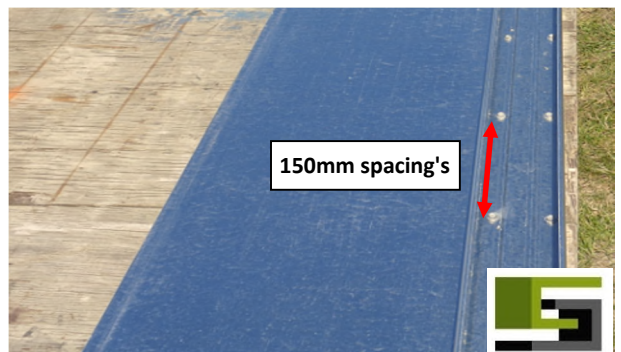



Before installing a B300, place two short pieces of material at each end of where the B300 will be located underneath the ceiling panels. This will hold the B300 flush to the bottom of the ceiling ready to be screwed.

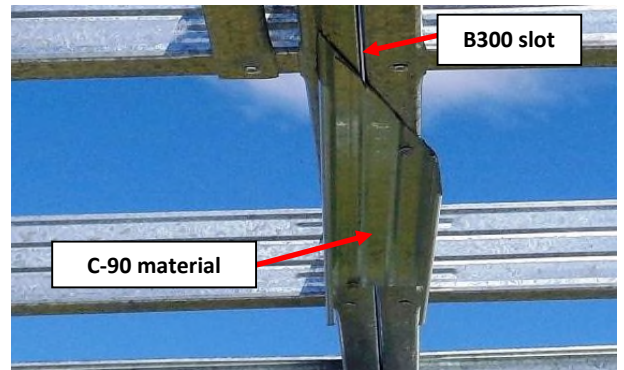

Place the B300 in the slot formed between the two ceiling panels as described in the previous chapter.

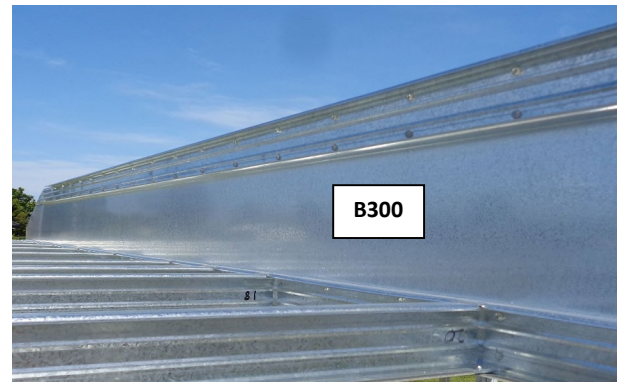

Secure in place with 2 x 10g-16x16 screws every 150mm through the ceiling panels sandwiching the B300.

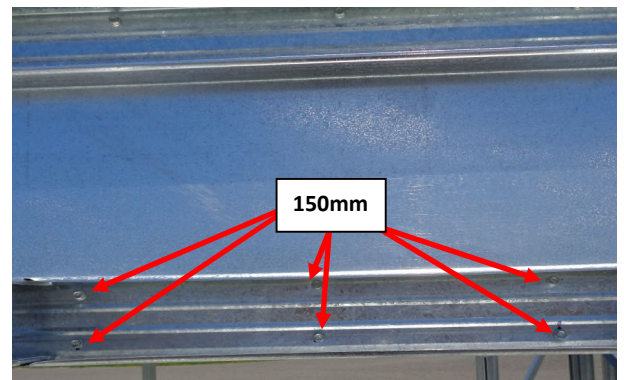

The top chord restraint of the B300 can now be fixed in place at the spacing's specified on the layout. Cut a 1m length of strap bracing and place half of the strap brace either side and perpendicular to the top chord. Fix the strap to the top chord with the number of 10g-16x16 screws specified on the layout.





Ensure the B300 is perpendicular to the ground. Screw each end of the strap to a ceiling panel and Top Chord with minimum 2 x 10g-16x16 screws each end.

Ensure the strap is taut on each side. Once this has been done the B300 can be shaped to fit within the roof if required.

There are several styles to form the top chord of a B300 to cater for different strength requirements. The supplied ScotLayout will have information relating to the specific B300 top chord style to be formed.

The adjacent illustration is a B300 as explained throughout this chapter.

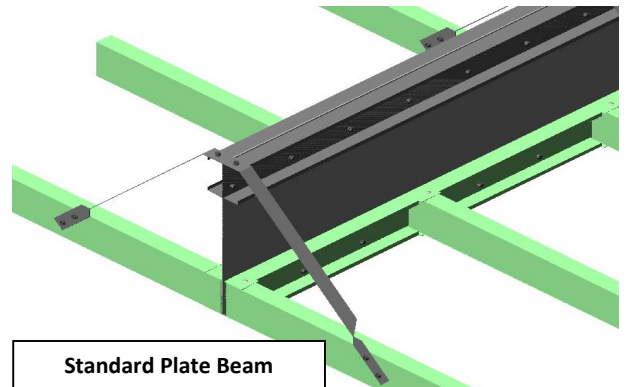
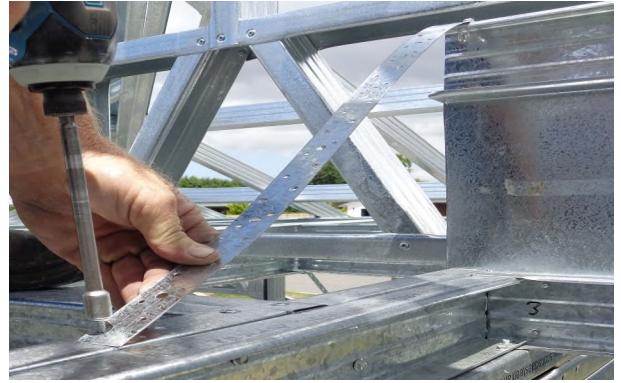

Reinforced Plate Beams

BC (bottom chord) screwed through ceiling panels at 150mm centres.
TP (top plate) connection "C" section material lengths screwed at 150mm centres.

Reinforcing member "C" section material lengths screwed at 150mm centres.

Strap material 25-30mm wide x 0.75 -1.15mm thick metal strapping.

Note: Chord reinforcements must be continuous and must not be joined. They are to be attached with 10g-16x16 tek screws.

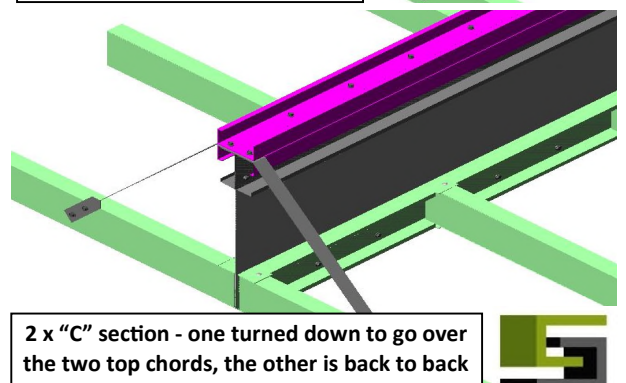
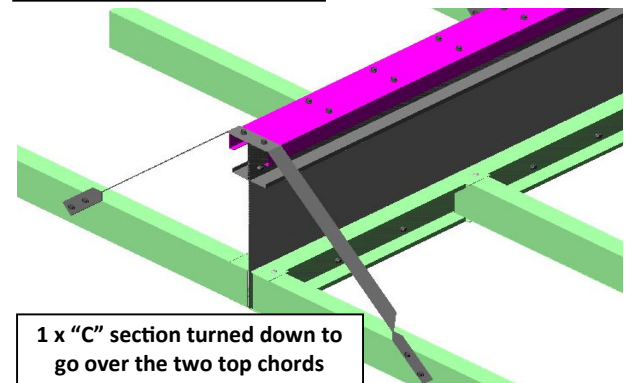



Before installing any Support Frames, the installer must read and understand the ScotLayout. Turn to the Support Frame page and take note of the Orientation Hole and Support Frame number.

Roof Panels require support frames sitting directly under them. They need to be positioned or screwed in place prior to erecting the roof panels. Typically ridge or apex supports would be installed first.

In the example: Support S20 position is 1770mm from the outside of the structure. Mark S20's position with a marker pen on the ceiling panel prior to fixing into position. (a chalk line can be used to provide a straight line between each end measurement) Use the minimum amount of screws at first, in case the support frame requires further adjustment. Work on a specific area of the building, in this case we need S16, S17, S19, & S20 in position before R30 and R31 can be installed. Once the roof looks correct, begin the screw-off process including attaching the twist ties.

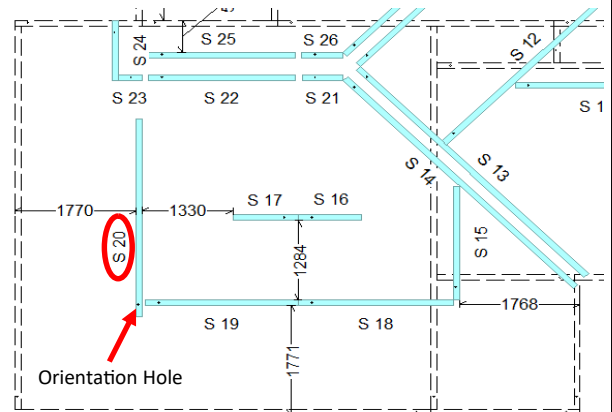

The orientation hole is always located in the bottom chord 100mm from the end. This should be identified prior to positioning the support frame.

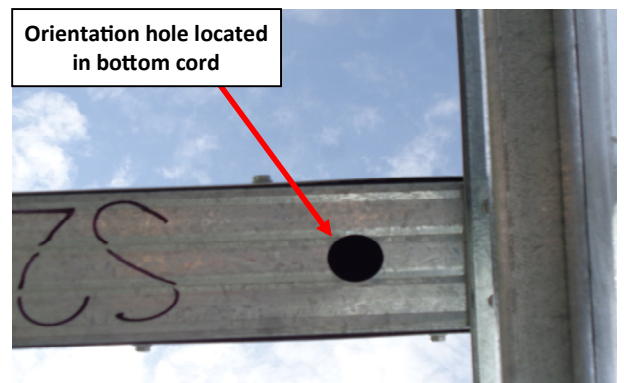

If the Support Frame needs to be plated, the screws must be spaced every 150mm apart around the perimeter of the plate. Supports should be plated by the manufacturer before delivery. If this has not been done apply the plate to the Support Frame before installation using Tek screws. Rivets can be substituted for 10g-16x16 screws if required.

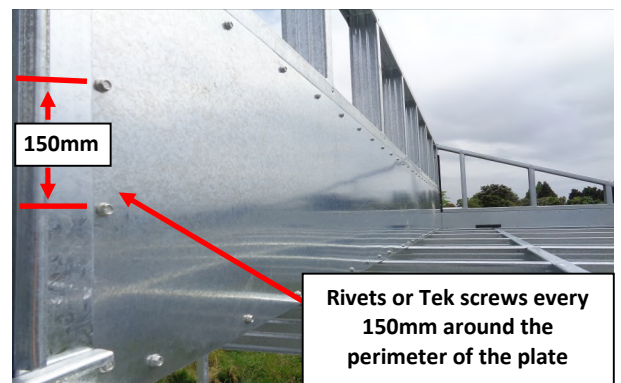



When Support Frames are required to provide support for Ceiling Frames that tek screws are not suitable for, twisted straps called "Twist Tie's" can be used to provide this support. Most hardware stores stock this bracket or something very similar.

Typically two 10g-16x16 screws are suitable as per the picture below.

To attach a ceiling to the underside of a Support Frame, screw Tek screws through the ceiling rafter that crosses the Support Frame bottom chord prior to installing the twist ties as per the adjacent images.

Alternately, the screws can be screwed into the ceiling through the support frame from above.

Recommended screws should be used on each crossing ceiling member.

If specified on the ceiling layout, fix a twist tie with 10g-16x16 screws to every second ceiling rafter. Good practice would be to alternate the brackets on either side of the Support Frame.

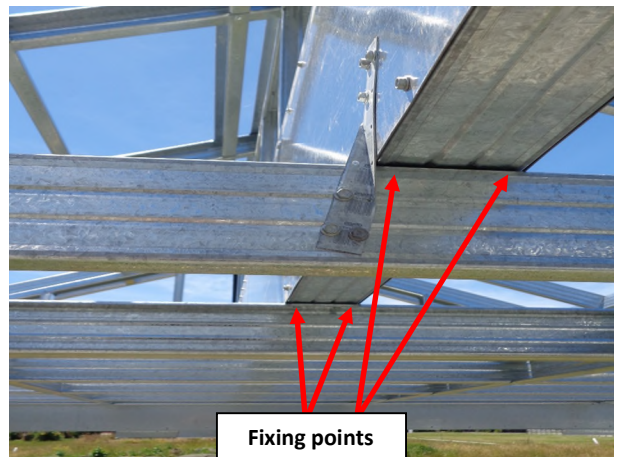
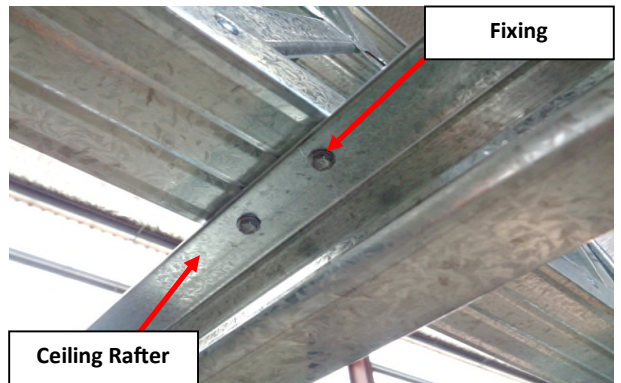



Support Frames can sometimes sit directly on top of the wall plate at the same level as the surrounding Ceiling Panels. This provides support for the ceiling as well as providing extra strength for the bottom chord of the Support Frame.

The adjacent ScotLayout image shows what a typical Ceiling Panel Layout looks like when a Support Frame is at the same level as the Ceilings.

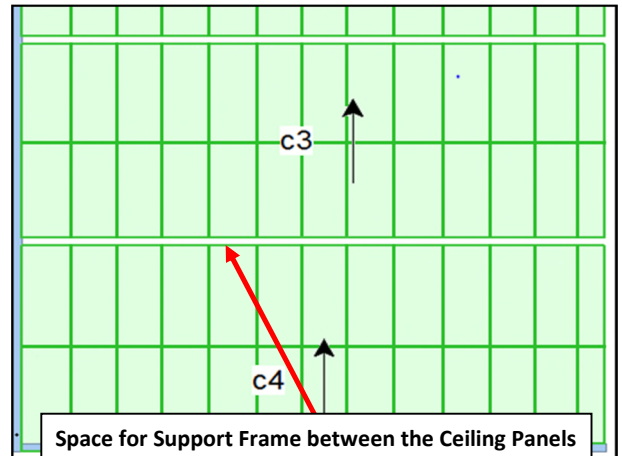

To achieve this configuration, place the Support Frame next to the Ceiling Panel so the Support Frame sits directly on the top plate. Then fix the ceiling with 2/10g-16x16 screws at centres specified on the layout into the Support Frame, the ceiling bottom chord and diagonals where possible. Place the next Ceiling Frame in position next to the Support Frame and secure in place with Tek screws as per the previous Ceiling Panel.

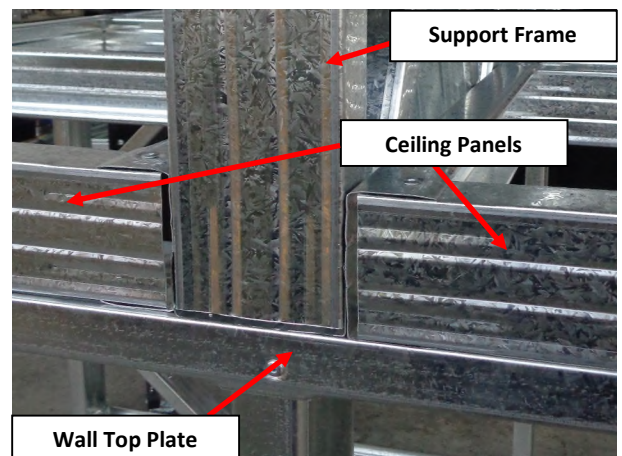

The image on the right shows a completed Support Frame utilising adjacent Ceiling Panels to provide reinforcement for the Support Frame bottom chord.

Consult the layout for additional support frame hold downs.





At times the engineering will require a Support Frame to have a single or a double reinforced top chord. This is where a piece of C-90 material (of the same gauge as the Support Frame) is screwed to both sides of the Support Frame lattice top chord with Tek screws. This is shown in the adjacent image.

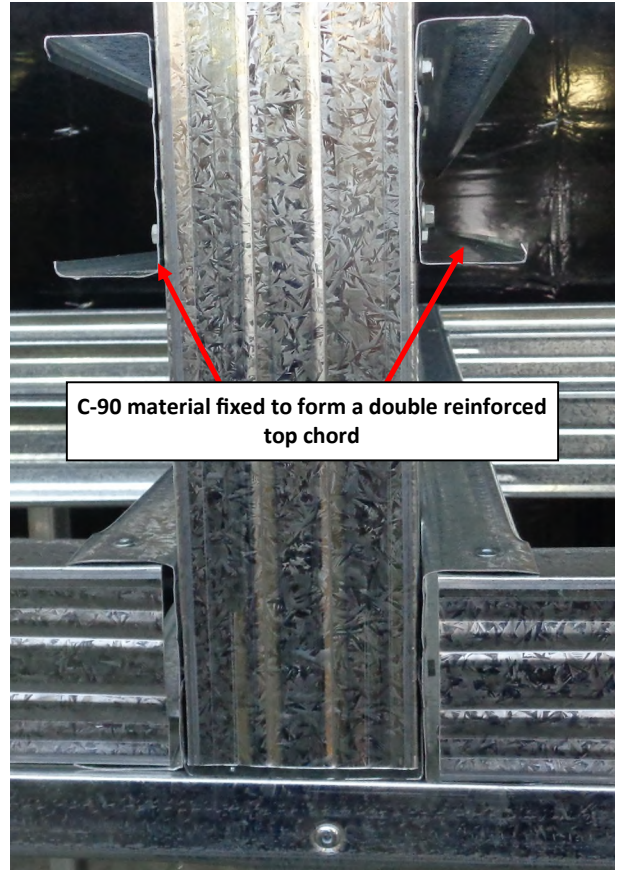

Chord reinforcements should be fixed at every diagonal member as close to the edge of the reinforcing member as possible. Another Tek screw must be placed through the reinforcing member into the lattice chord directly above it.





Before erecting roof panels, review ScotLayout and place roof panels around the structure in the correct orientation ready to lift into position.

Sometimes it is easier to stand intermediate support frames after the roof has been attached to the ridge support. These intermediate supports can be left standing next to the ridge support frame prior to the roof being lifted into position. Then its just a case of placing them to the pre-marked position on the ceiling panel.

Start by installing the roof panels where the roof forms a hip and work away from it towards the valley areas. This provides a good square reference to work away from.

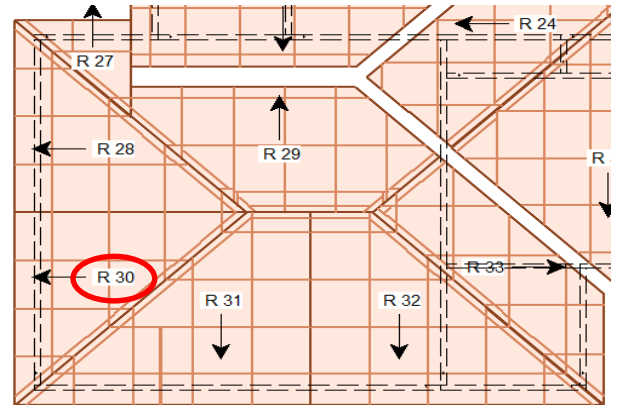

From the ScotLayout find the measurement indicating the overhang of the soffit.

This can be supplied two ways.

One is the horizontal measurement from the wall to the bottom of the roof panel

The other is the measurement "on the rake" (down the rafter)

Example: Measurement is 450mm from the wall to the bottom position of the bottom plate of the roof panel.



Measurement is 496mm from the wall to the bottom position of the bottom plate of the roof panel.





The soffit distance is 450mm. Measure from the bottom of the roof frame along the same angle of 25 deg rake of the roof to the ceiling frame. It should measure 496mm.

To work out the length of the pitch.

Example: *Soffit divide by Cos (pitch)*

$$450 \div \cos(25^\circ) = 496\text{mm}$$

If your soffit is 450mm from the wall to the bottom plate of the roof panel, mark 496mm up from the bottom plate of the roof panel, so you know visually where the roof panel should be resting.



Transfer the measurement to all roof panel overhangs with an ink marker pen, remembering that the horizontal nog members need to be facing down towards the bottom of the panel.

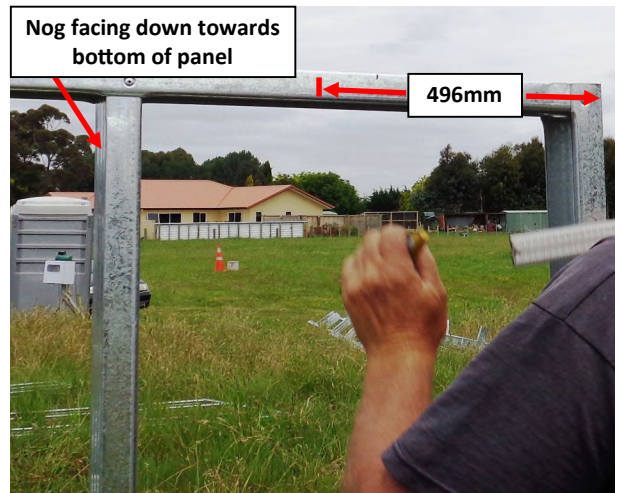

Starting on a hip roof frame as shown. Loosely fix the roof panel to the ceiling as the starting point.





When installing roof frames keep sighting from the ground up the length of the roof panel for dips or humps. These can be removed by tweaking the intermediate support frame.

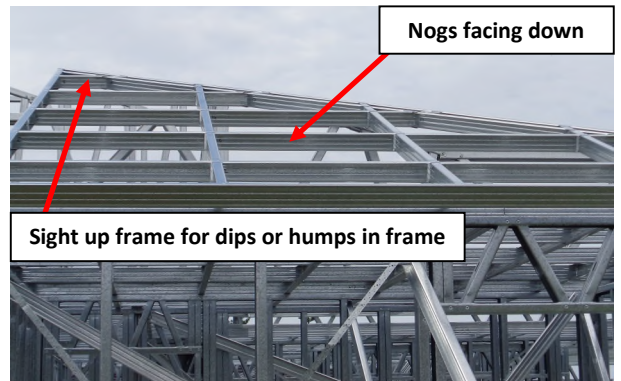

If the roof panel has a dip, move the support frame towards the external wall.

After all roof panels are perfectly straight the support and roof frames can be screwed-off with the required hold downs, braces and brackets.

Refer to the roof layout for roof hold down types and specific locations.

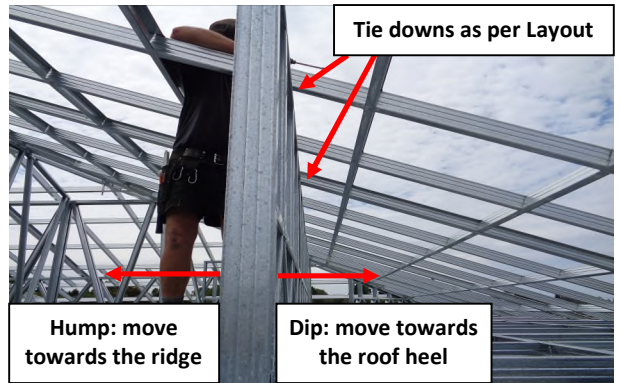

In this example twist ties need to be connected as per the tie down details around the external walls using specified screws.

Screw the rafter, ceiling and top plate of the wall, tying the three items together.

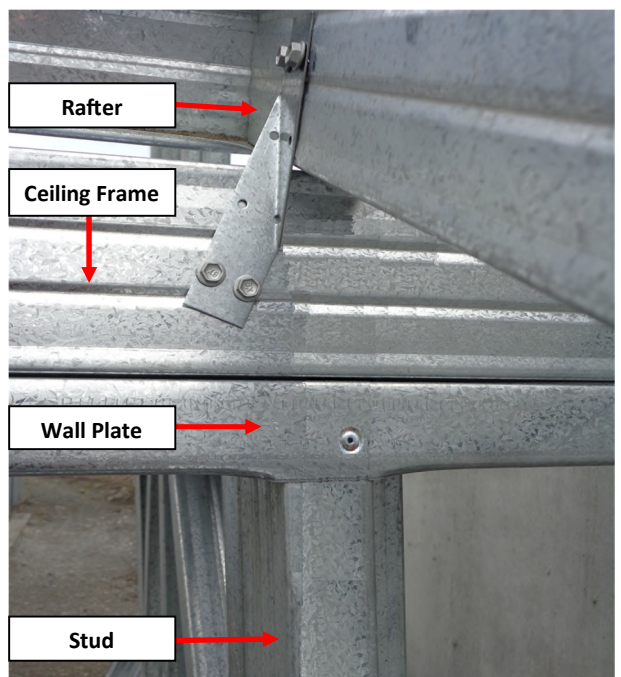



Fixing the Hip

Fixing the roof panels together on a hip can be hindered because of a nog line put in the frame for fixing the hip ridge cap. Having a 28mm hole placed at fixing locations during the design stage or drilling a 13mm hole in the nog member allows the Hex driver and Tek screw to reach the perimeter hip member.

Using the long hex driver, screw the hips together at the lower part of the "C" Section. The fixing points should be secured at 300mm centers.

Panels should typically be joined together with 2/10g-16x16 tek screws at each nog line and each end of the joining rafter.

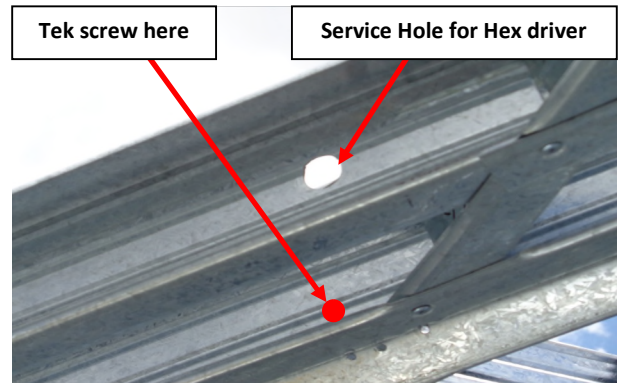



Forming Box Valleys in a Panel Roof (for sheet roofing)

After erecting all roof panels and installing the hold downs, the valley can be measured and screwed off.



Measure the distance between the two panels as per the adjacent image.

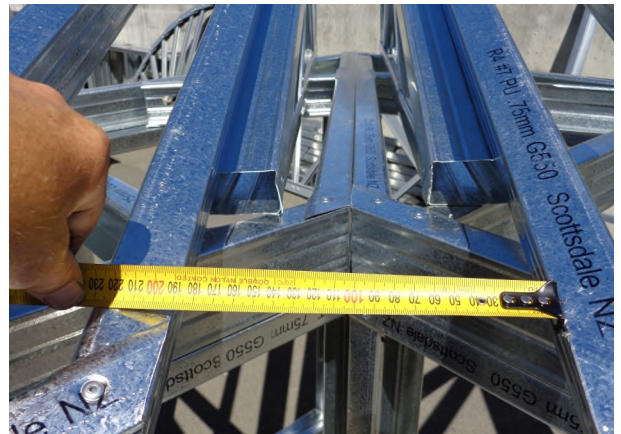

Measure the depth and width gap of the valley for any discrepancies.





Fold up a tray to fit in the valley pocket formed by the roof panels.



Screw the valley tray in place using wafer head Tek screws through the top edge of the valley tray into the roof panel.

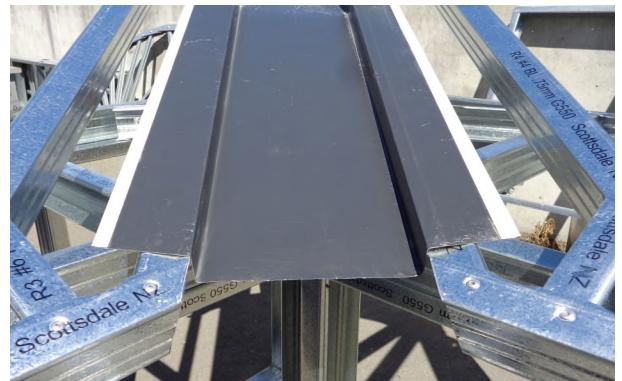

After the valley tray is fixed in place the bottom of the tray can be formed to fit the gutter by cutting along the lines drawn on the tray below. After all the valley trays have been installed the roof is now ready for the roofing iron to be attached.



Example of a finished Box Valley





Forming Box Valleys (For a Tiled Roof)

The centre of the V shaped valley tray should rest in-between the two roof panels. It is recommended that a bead of silicon be applied to the underside of the valley tray to prevent any metallic rub.

To make valleys you will need a folding machine or have a local company fold them.



Once the valley tray has been located, the battens can be placed either side for the roofing fixing.

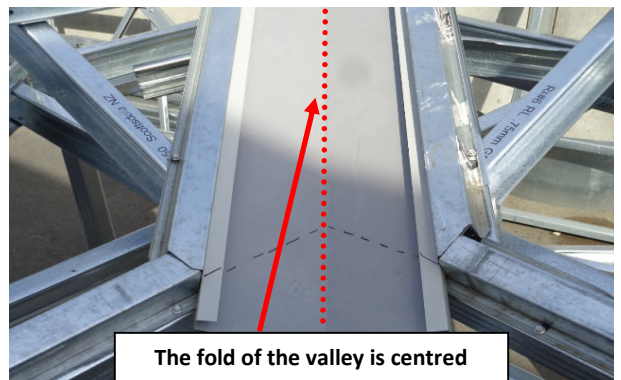

Fix the battens both sides of the valley using Tek screws.





Once all the battens are fixed down, the valley tray can be installed.



After seating the tray, place one Tek screw each side above the return lip creating a friction fit connection. Spacing of the screws to be no more than 900mm apart up the valley. Notice the screw is pushing down on the return lip to create tension. **Do not** screw under the return lip.

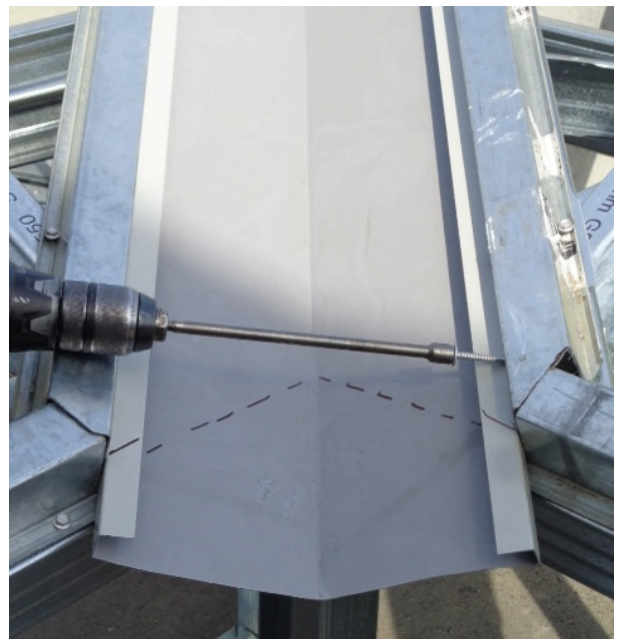



Before Soffits are installed, a 600mm wide length of building wrap is attached to the wall as seen in the adjacent image.

To connect building wrap to the frames, use a spray on glue. Begin by spraying glue on to the ceiling panel, wall, top plate and any studs that come in contact with the wrap. Stretch out the building wrap pushing it firmly on to the glue.

A wafer head Tek screw can be used on all thicknesses. A pneumatic staple gun could be used on 0.55mm steel.



Spray glue on the ceiling panel, top chord, and the stud.



Once the building wrap is attached, the soffit framing can be installed using Tek screws fixed to every stud and the roof panel making sure the outriggers are level and square to the building.

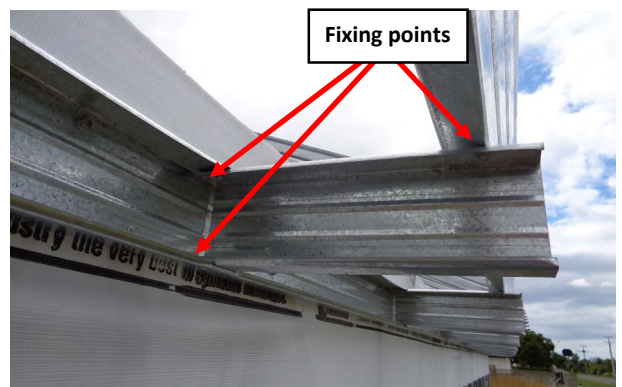



Once the soffit frame is installed you can begin to attach the fascia bracket.

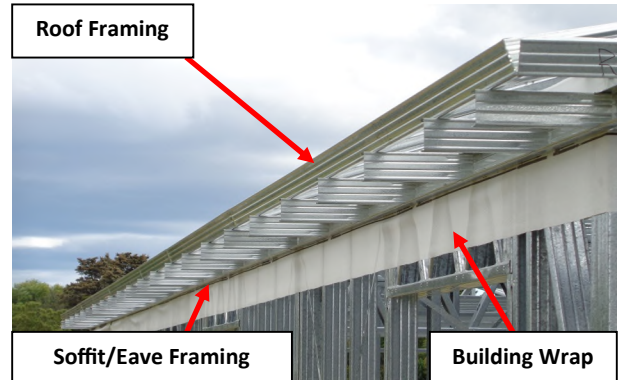

Ensure the bracket has at least 3-4 mm gap under the roofing material height to allow the roofing to go over the top of the fascia bracket. When satisfied the bracket is the correct height, fix with one Tek screw.

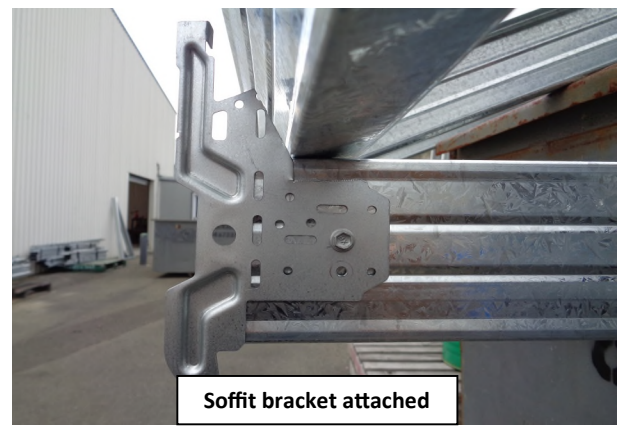

Plumb the fascia bracket using a level and fix in place. Repeat the procedure at the other end of the fascia line then run a string line between the two brackets. Fix the remaining brackets using the string line as a height guide.



Fascia brackets can also be fixed in the following way.

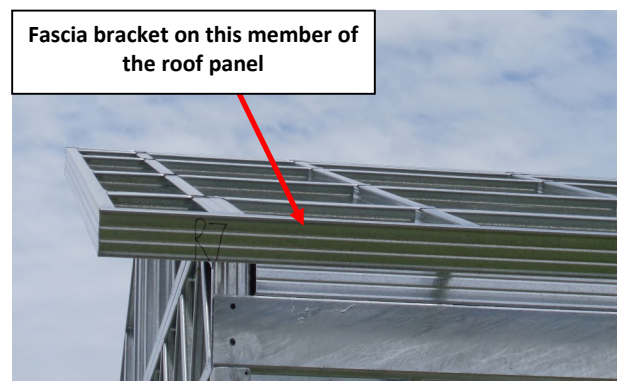



Connect a simple right angle bracket to the bottom plate of the roof panel, making sure the bracket does not protrude above the top edge of the roof panel.

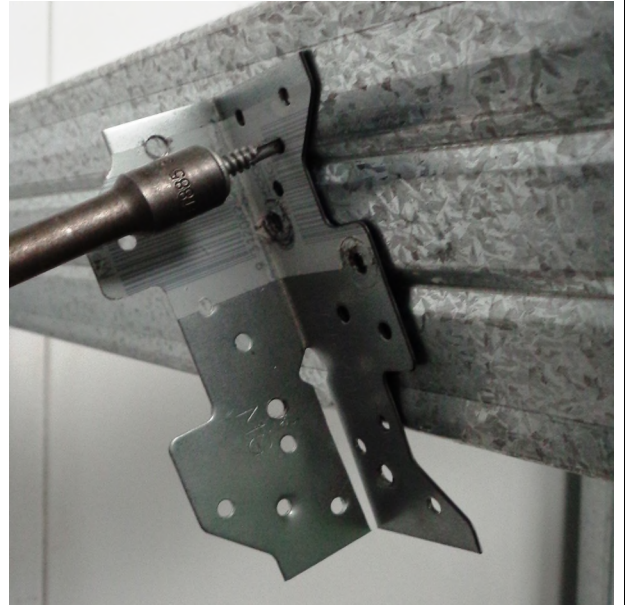

Securely fix the bracket with Tek screws. The brackets can be sourced from most Hardware Suppliers or folded on site.

Cut the fascia bracket at the correct angle so that the fascia bracket can be fitted plumb as the example in the image on the right shows. Fix with Tek screws making certain the bracket is not protruding above the top of the roof panel. Ensure there is enough of a gap for the roofing material to pass over the fascia.

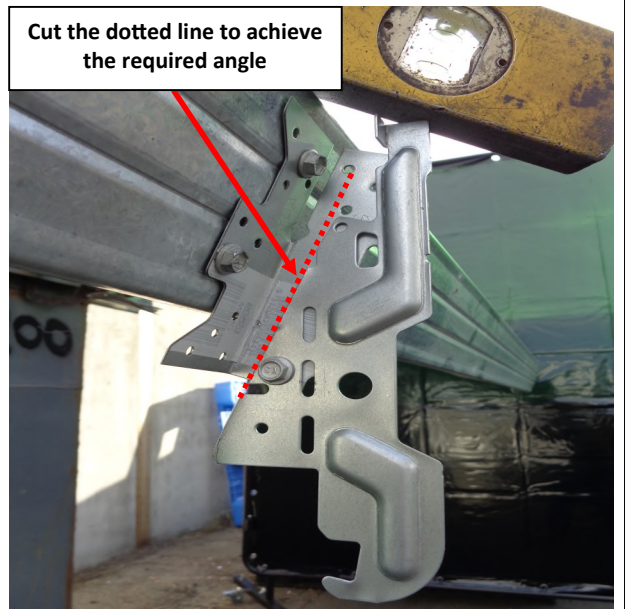

Plumb the fascia bracket and secure with Tek screws





Notes





How to Install Roof Trusses

The following instructions are a guide only, and specific details should be supplied by the truss manufacturer.

Prior to placing trusses on to the wall framing, it is often beneficial to mark the locations of the trusses on the framing top plates in accordance with the supplied ScotLayout.

Tip: Before trusses are separated from their packs the top chord batten locations can be marked with a straight edge at the required locations to assist with installing the roof battens when the trusses are standing upright on the framing.

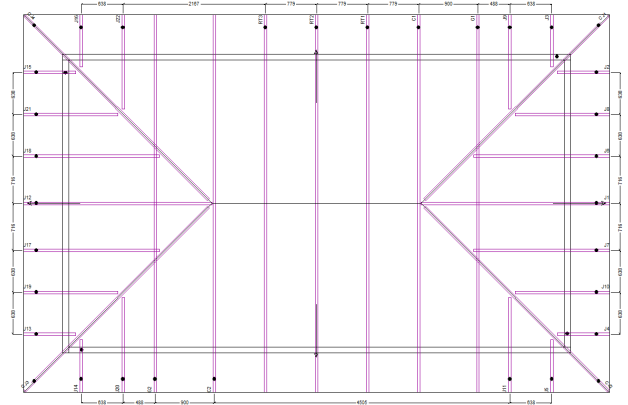

Hip and Dutch Gable Installation

Girder and Truncated Girder Trusses should be set out first as they are confined to specific locations due to fitting with other trusses.

Once Truncated Girder Trusses or Dutch Gable Trusses are placed in their required location, the centre Jack Truss can be placed in its corresponding location and connected to the Girder. This will hold the Truncated Girder in a plumb (vertical) location. The remaining Jack Trusses can be located and connected.

Where it is not practical to brace the Girder with another truss, install the next 2-3 parallel trusses then brace the top of the Girder back to the bottom of one of the other installed trusses. Repeat the brace in the opposite direction to form a rigid group.

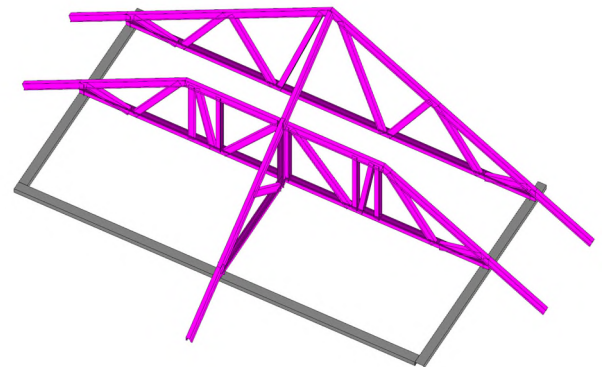

Subsequent Trusses

As each subsequent truss is installed moving away from the first truss, a temporary batten should be attached to the top chord of each truss to tie it to the first braced truss. The separation distance at the bottom must be the same as the top, ensuring the trusses are located on the set out marks and plumb.

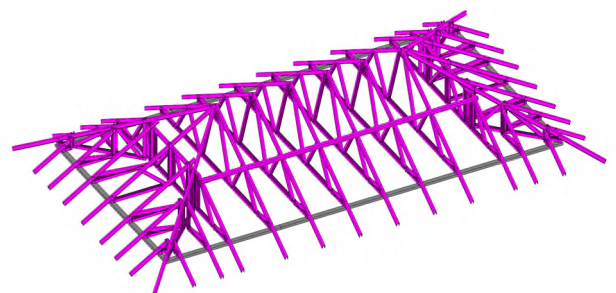



Gable Roof Truss Installation

Some Gable End Trusses are designed to be fully supported by a wall directly below. It cannot act as a clear span truss. Trusses of these types typically have only vertical members in them with one or two small diagonal members.

If the Gable Wall does not extend up to the underside of the roof and a Gable Truss is required on top of the end wall, there are two ways to install this truss.

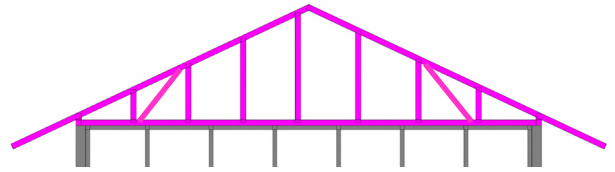

Ground Prop

Place the truss in the required location on top of the end wall. Attach a temporary brace to the top of the truss, or to a high location on the truss. Ensure the truss is plumb then fix the bottom end of the brace to a ground anchor (peg or stake driven into the ground).

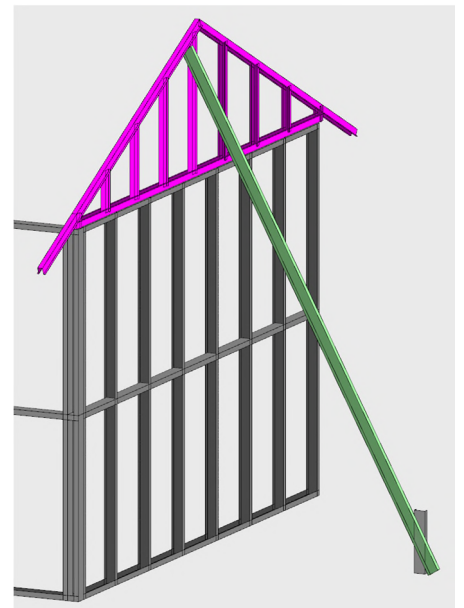

Wall Prop

Place the truss in the required location on top of the end wall. Attach a brace to the face of the wall below with the top end up to, or slightly extending past the top of the truss. Fix the brace to the truss to hold it upright. Once 2-3 trusses have been installed parallel to the Gable Truss, it can then be plumbed and the top braced back to the bottom of another truss.

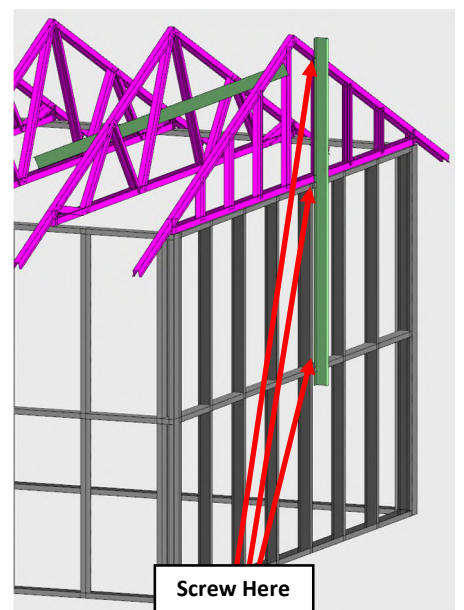



Jack Truss Installation

Jack Trusses are best installed, beginning in the centre and moving outwards.

Jack to Girder connections can be done several ways. The correct connecting method for each project should be portrayed on the ScotLayout supplied from the manufacturer.

Each Jack Truss should line up closely with a vertical web in the Girder Truss.

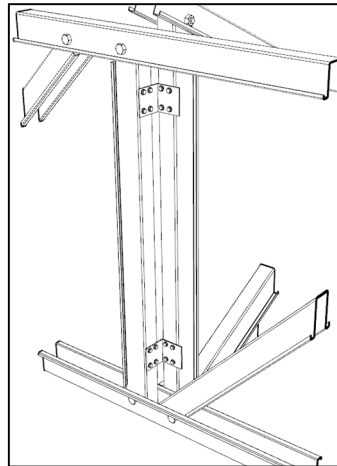

Jack to Girder Truss connected with two 90° brackets

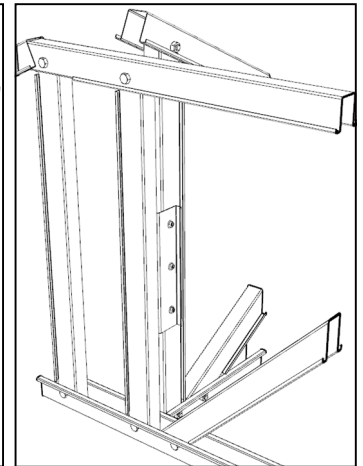

250 x 0.95mm Truss Profile fixed with Tek screws required for the load

Corner Jack Installation

Corner Jack Trusses can be connected to the Girder Truss by brackets at either the top and bottom chords or by connecting the webs together at the top and bottom with an angled bent plate.

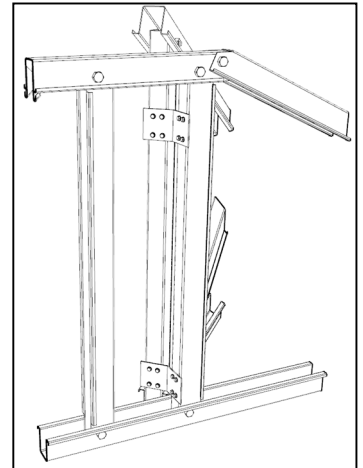

Jack to Corner Jack Installation

Jack to Corner Jack can be connected by brackets at either the top and bottom chords or by connecting the webs together at the top and bottom with an angled bent plate.

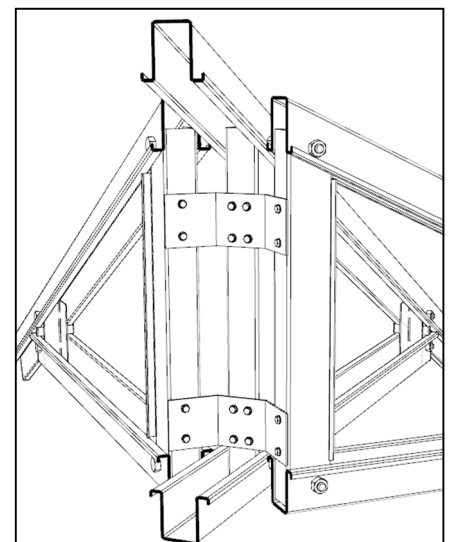

Jack trusses joined to Corner Jack with 3mm 135° angle brackets





Brackets and Fixings

Outlined in this section are different ways to secure trusses to framing in many different forms. It also includes ways to form truss to truss connections.

Connection capacities must be confirmed by your engineer.

Truss Hold Down Brackets

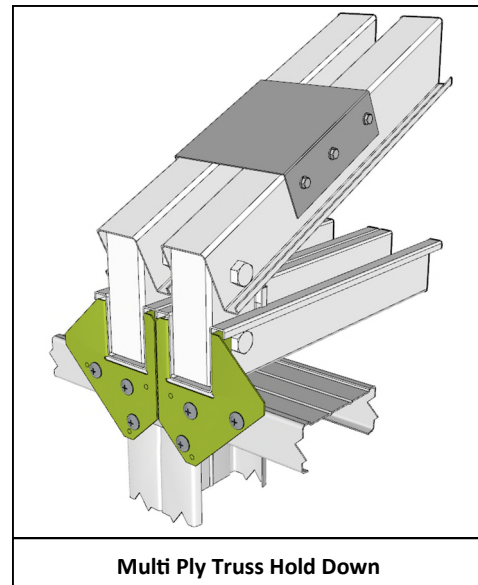
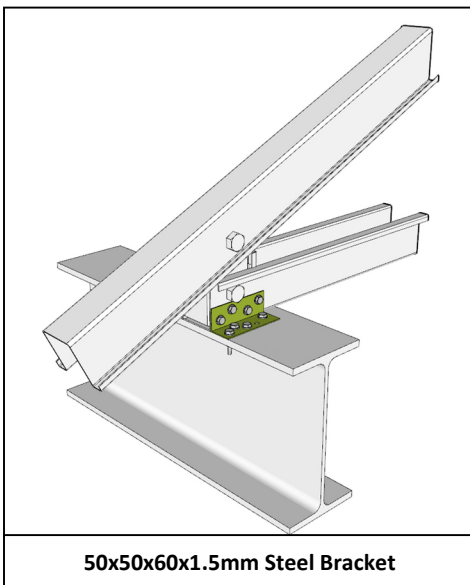
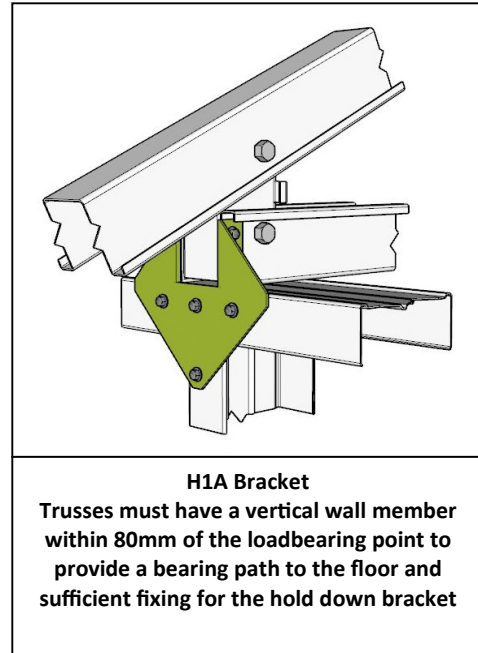
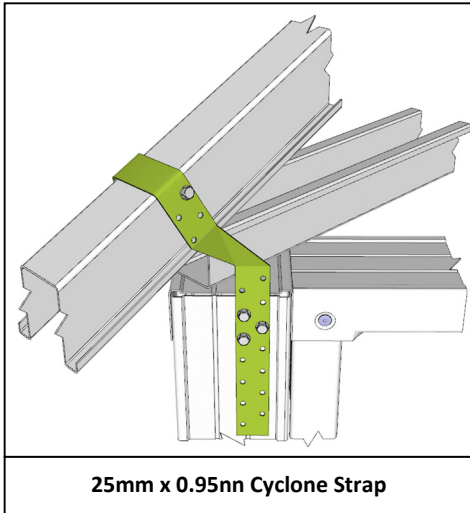



Brackets and Fixings

Outlined in this section are different ways to secure trusses to framing in many different forms. It also includes ways to form truss to truss connections.

Connection capacities must be confirmed by your engineer.

Truss to Truss Connections

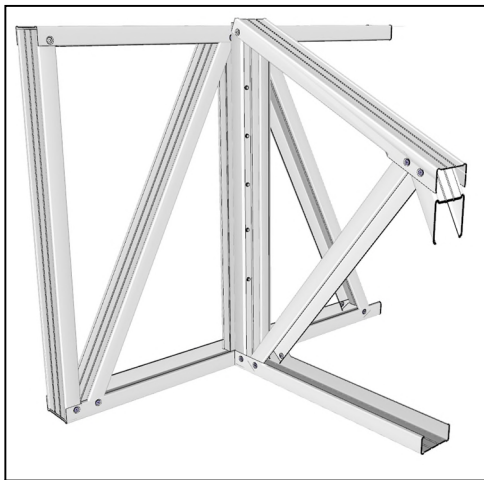

C Section Jack Truss to C Section Girder

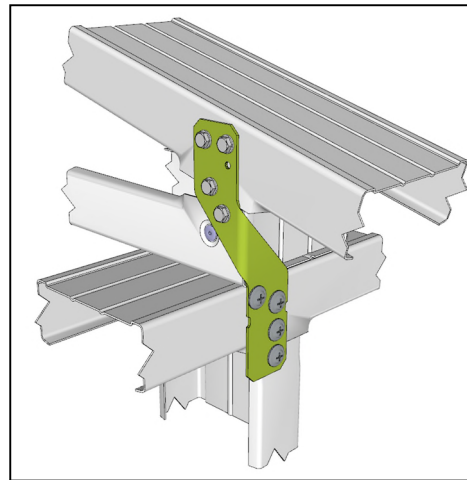

Typical C Section Truss Hold Down

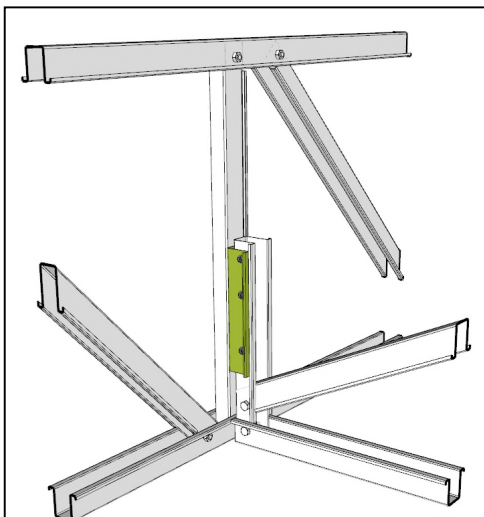

Heel Extension Connection to Girder

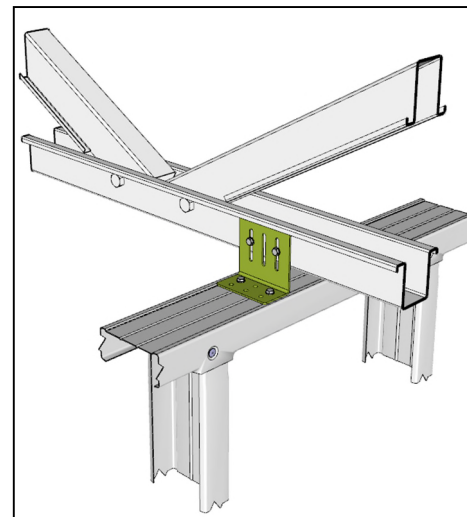

Truss to Internal Non-Loadbearing Wall





Hip Apex Connection

At the apex of a hip, many jack top chords converge at the same point. These can be easily connected together with an apex plate. It can be constructed on site or supplied by the truss manufacturer. A piece of 0.75mm steel plate, measuring approximately 170mm x 250mm is required. This is first attached to the apex truss with Tek screws. A cut is made in the plate directly above the centre jack truss until approximately 60mm from the edge that is attached to the apex truss. This will allow the two sides to be bent downward and the edges of the cut to overlap above the centre jack. Each truss should be attached to the plate with Tek screws.

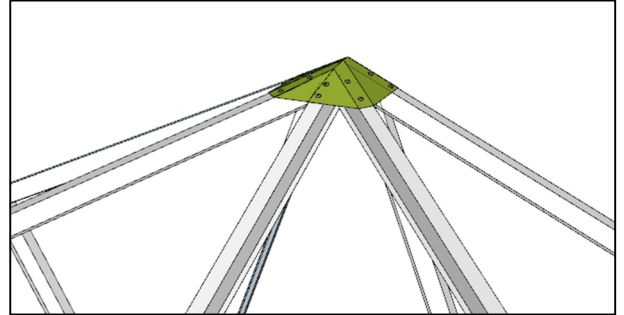

Truss Bracing

Truss Bracing should be applied to the roof area to provide both bracing as well as lateral restraints.

A gable roof requires a diagonal brace inside the roof space to prevent the end truss moving out of plumb.

Ideally it will be from near the top of the gable truss back to the bottom chord of another truss on an approx. 45° angle.

A batten on the bottom chord should be screwed to the trusses so they are kept parallel to each other.

Roof cross bracing should be fixed at each end of the brace. One end should be located at the apex of the truss and the other directly above the loadbearing heel. The lower tail of the strap should be bent down and fixed to the top plate or stud supporting the truss. Screw requirements are dependant on engineers specifications.

Note: Strap bracing is available in different thicknesses. Ensure correct thickness is being used to match engineering specifications.

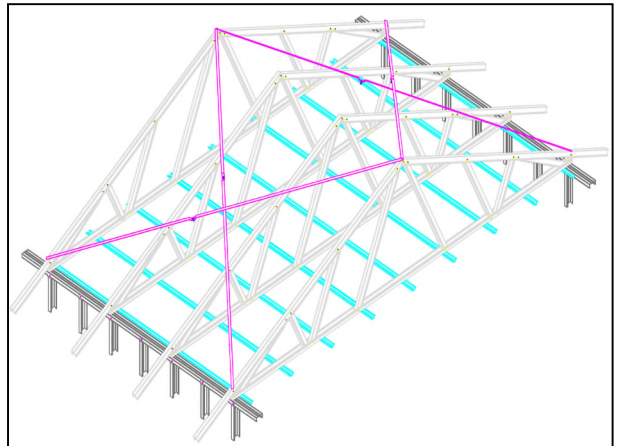

Strap bracing should be tensioned with tensioners to ensure it is taut. Do not over tighten.

Truss Bracing Over a Cantilever

Where roof bracing finishes on trusses that are cantilevering over a supporting wall, the force generated by the strap bracing must be transferred to the supporting structure. In cantilever trusses this can be achieved by adding additional members as shown in the adjacent image.

Blocking should be applied parallel to the supporting structure on either side of the truss heel where the strap bracing terminates.

Additional blocking should be attached to the same truss end, back to the supporting structure, close to where the adjacent truss is supported. Fix each end of all blocking with a minimum of two Tek screws.

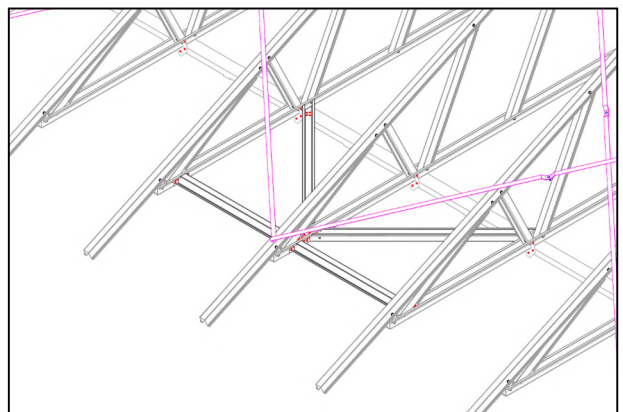



Battens

Battens can be fixed to steel trusses quickly and easily using a Tek screw for steel top hat battens and Wing-Tek screw for timber battens.



Wing-Tek screws have small reamer wings that drill through wood/fibre cement and automatically snap off when they come in contact with steel. They are located on the shaft between the thread and the self drilling point. They are designed to cut a larger hole through softer material so the screw thread doesn't engage with anything other than the steel.

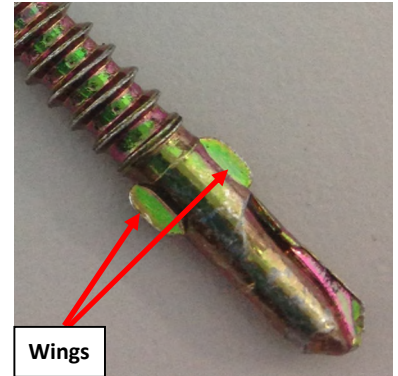

Steel battens are typically fixed through both lips. Minimum requirement is one Tek screw per side. More screws may be required in high wind areas. Check your engineering requirements to confirm fixing needs.



Timber battens are typically fixed directly through the batten with at least one Wing-Tek screw.

More screws may be required in high wind areas. Check your engineering requirements to confirm fixing needs.





Plumb and Level

When using a level on the Top Hat Profile, care must be taken to place the level across similar parts of the truss. If one end of the level is resting on the lip of the profile the other end must also be. The level can also be placed against the web of the top hat profile when measuring for plumb.



Soffits, Fascia and Brackets

Fascia Brackets can be attached in many different ways. These depend on how the truss overhang has been produced from the fabricator. If the lips of the truss profile have been cut off then the fascia bracket can be directly screwed to the web of the truss.

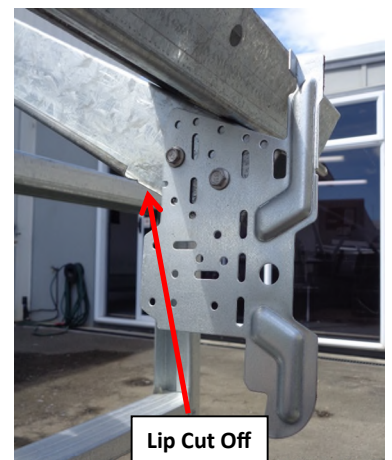

If the lips of the profile have not been cut off then the fascia bracket can still be attached with the help of either a small 90° bent bracket or a piece or "C" Section profile with one lip flattened.





Soffits, Fascia Brackets continued

Some manufacturers prefer to leave the lips attached to the truss overhang for safety, as it can be very sharp and a significant hazard on site until the fascia is installed.

If this is the case when your trusses arrive, another way to attach the fascia bracket is to squash one side of the lip on the overhang back against the flange of the profile. If this has not been done in the factory then it can be done with pliers if it is a light gauge, or a pair of flatteners the same as used with the panel installation.

Forming Soffits

Most fascia installers recommend that the fascia is installed prior to installing the soffit framing. Check with your fascia installer for the correct procedure and the height of soffit framing.

Soffit framing can be formed many different ways. Illustrated here are two ways.

If the description here does not suit your project then do not use these methods.

Using the Truss Profile

Most fascia systems have a vertical drop greater than the top cord depth. This requires a soffit to be framed back to the wall and it needs a “dropper”. A piece of steel to attach the horizontal framing to the truss top cord in a vertical orientation. Depending on the fascia bracket the dropper is sometimes not needed.

Note: This will sometimes be included in the design of the truss from the factory.

Using the C Section Profile

Using the wider panel profile removes the need for a dropper as sometimes it can directly connect with the lower part of the truss overhang. It does provide better fixing ability to the fascia bracket and therefore does not need the dropper.

Fix the horizontal framing to the overhang and back into a flattened part of the “C” section fixed to the wall. Horizontal members should be installed level or tilted slightly towards the overhang (1/300) to encourage any water trapped on the soffit lining to move away from the building.





Overhang Supports

Sometimes truss designers utilise an overhang “doubler” to help provide strength to an overhang. This is usually when an overhang is longer than normal like on a corner jack.

An overhang doubler is typically screwed together through the lip with tek screws in the factory.

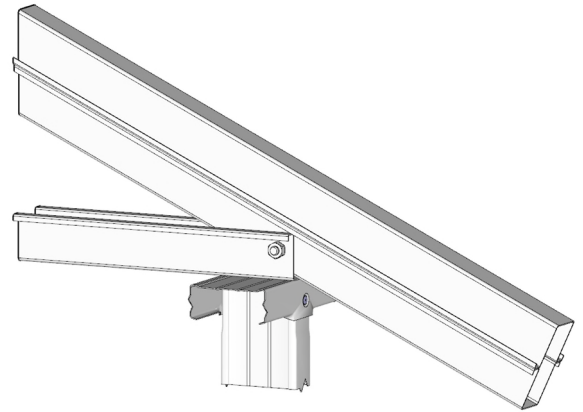

Multi Ply Trusses

Trusses subjected to large loads may require to be multi ply (more than one truss fixed together). Sometimes these are supplied as separate trusses so they can be easily lifted and then fixed together once in place.

The engineer/designer should supply fixing details highlighting the location where the joiner brackets should be located.

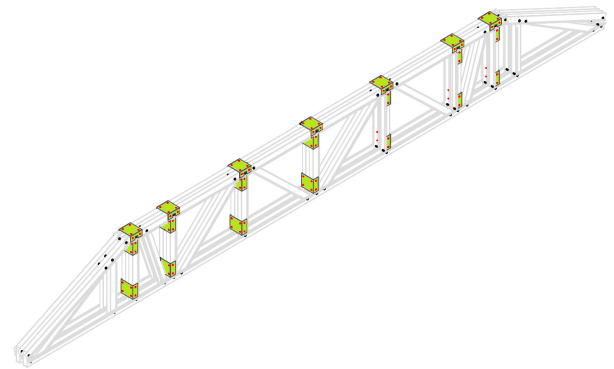

Multi Ply Trusses are typically joined together with a “U” Shaped bracket that is slipped over the hat section of two trusses and then screwed in place.

On Girder Trusses, “U” Shaped brackets should be placed at the top and bottom of all webs where another truss is connecting. Another “U” shaped bracket must be placed over the top chord of the truss above where the truss connects with the girder to prevent the top cords separating under load.

Multi Ply Trusses that are not carrying other truss loads should have brackets applied at the top and bottom of every second web in the truss.

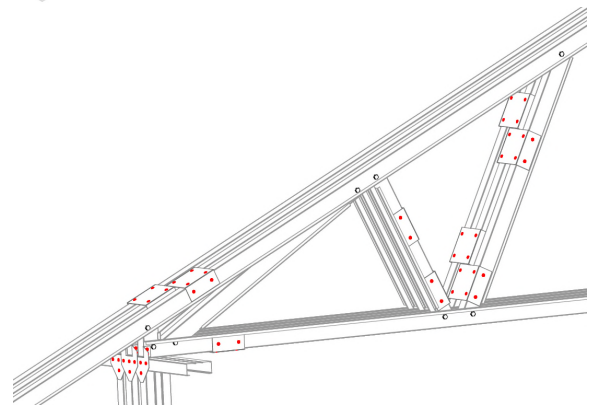

Some fabricators use a double ended nut to tie two trusses together. This is usually always fitted by the fabricator in the factory and prevents the truss from separating under load.

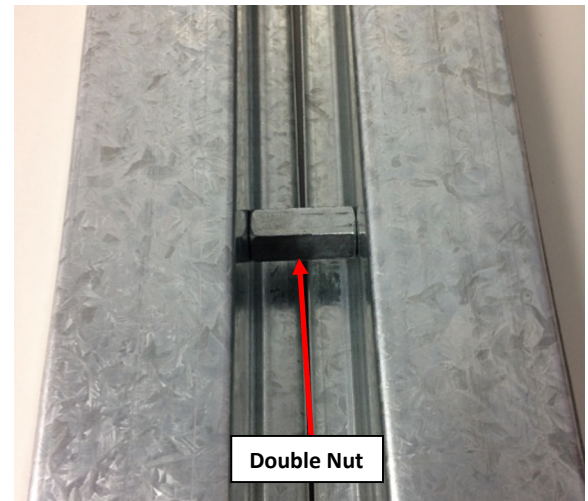



Hybrid Hip End

A hybrid system combines the best parts of both ScotTruss and ScotPanel systems. ScotTruss can achieve large spans, while the ScotPanel system allows installers to quickly complete large areas of a roof or ceiling ready for lining with only a few easily installed panels, reducing the amount of time required on site to fit smaller trusses.

Hybrid Hip Ends are formed with panels being supported by the exterior walls and a girder truss that would normally support multiple corner jacks and jack trusses.

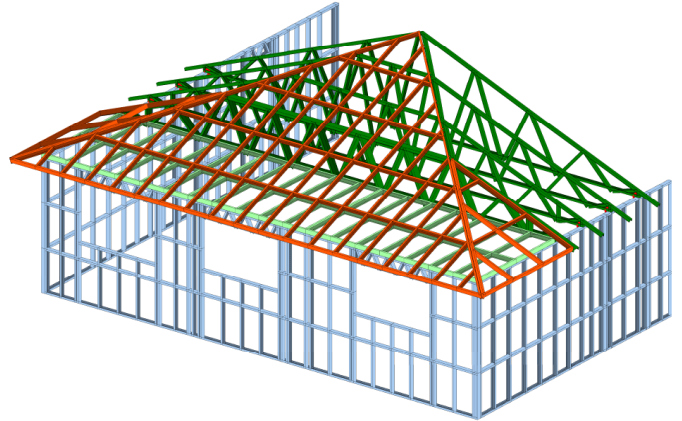

Hybrid Gable

Hybrid Gables are formed with panels to quickly achieve a gable overhang. This reduces the amount of time required later in the build.

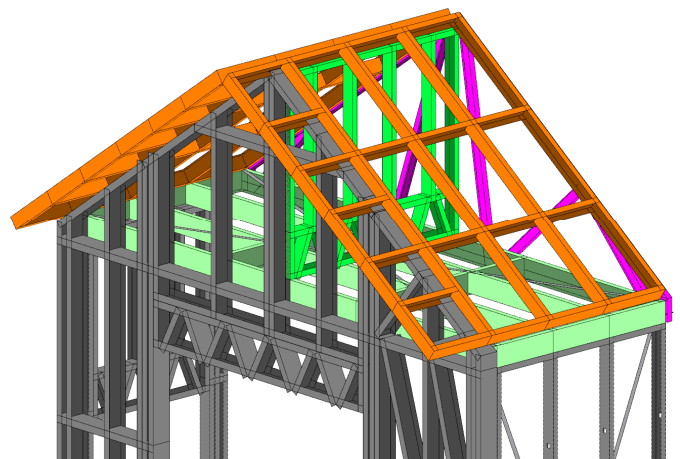



Hybrid Hip Installation Process

Hip End Hybrids are formed quickly and easily by first placing the ceiling panels on top of the wall frames. Ensure the ceiling panel is flush with the outside of the framing (sometimes if there is more than one ceiling panel this can cause a small gap between the frames). Ensure the ceiling panels are square by measuring from corner to corner and adjusting until the measurements are the same.

Screw down the ceiling panel at each corner. Further fixing will be added later.

Next, install the girder truss, at each end, up against the ceiling panel. Some hold down brackets need to be fixed to the truss prior to truss placement.

Note: Lips at the cut ends of the truss bottom chord may be slightly flared due to the cutting action of the Rollformer. Bend these lips inwards to form the correct profile shape at the ends of the truss.

Fix the ceiling panel to the truss with 45mm long Tek screws (if using a top hat truss), by ensuring the underside of the ceiling is at the correct height in relation to the bottom of the truss.

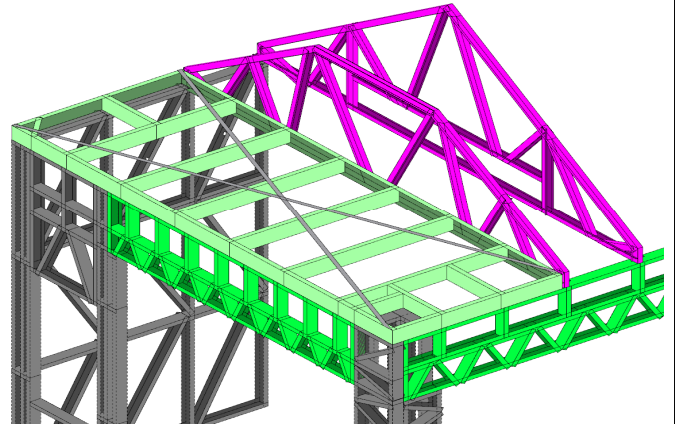

If the ceiling panel is positioned before placing the truss it makes it almost impossible to attach an H1A bracket correctly. The bracket should be connected to the truss bottom chord prior to truss placement if the ceiling panel is already positioned.

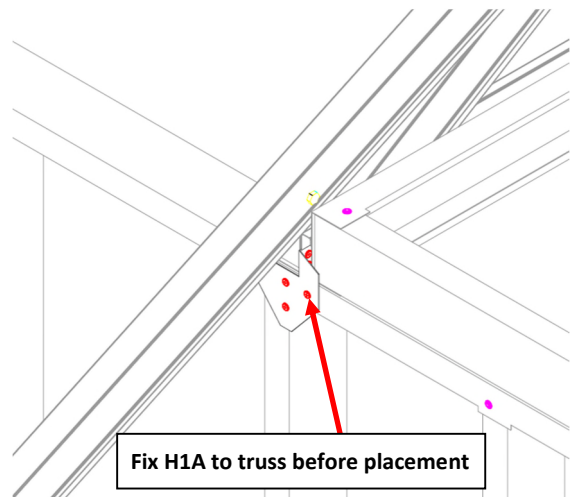

Placement of the apex truss at this point is optional.

Roof panel installation is next.

Side roof panels should be installed first. This is done by establishing the length of the overhang and marking the panel at the required length for correct placement, as shown in the roof panel section. Lay the side panel on top of the ceiling ensuring the overhang is square to the ceiling panel. Fix the roof panel down with a loosely tightened Tek screw near the outside edge of the ceiling panel. Then lift the top of the panel up to align with the top of future purlins or batten on top of the truss and fix the roof panel to the truss with 45mm screws at 600mm centers.

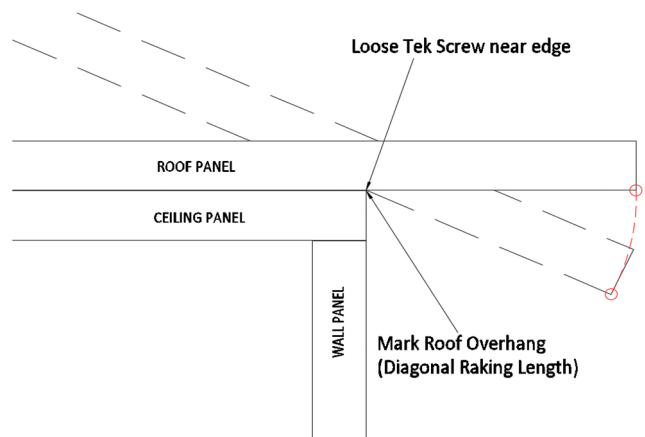



Check the truss is plumb and adjust roof panel accordingly by unscrewing the end furthest from the truss then re-screwing. The roof panel should meet the corner of the ceiling frame neatly.

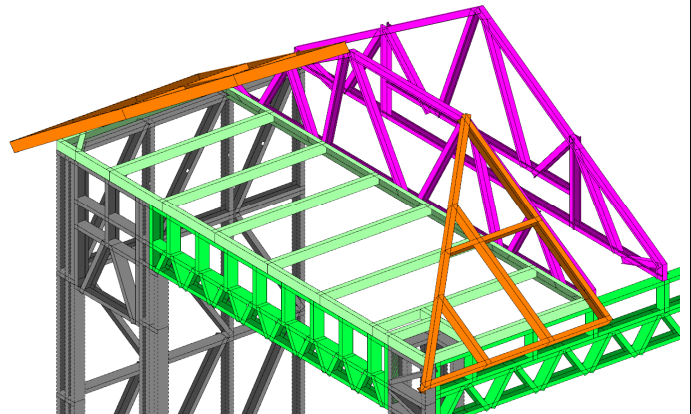

The end roof panel can now be installed, ensuring the over hang is correct and the corners meet neatly at the corner of the ceiling. Roof panels forming a hip should be screwed together through the "C" section where they meet at approx. 600mm centres. The roof panel passing over the girder should be initially screwed down with just Tek screws to hold it in place until hold down straps and brackets are in place.

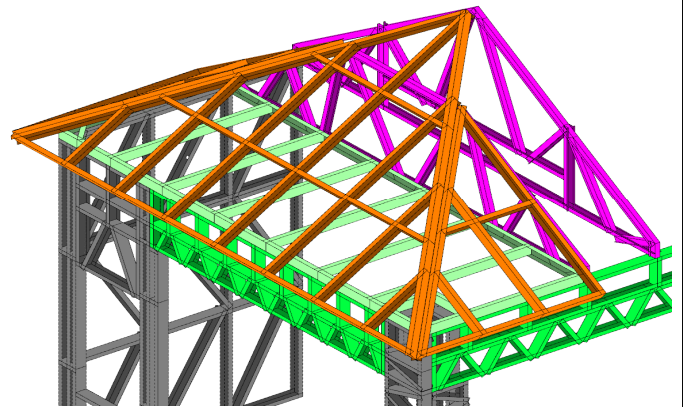

For sheet roofs, roof battens will join with the panels so the top of the batten is the same height as the top of the panel. This allows the sheeting to be screwed to the nog members of the panel.

For tile roofs, the batten will extend over the panel as normal.

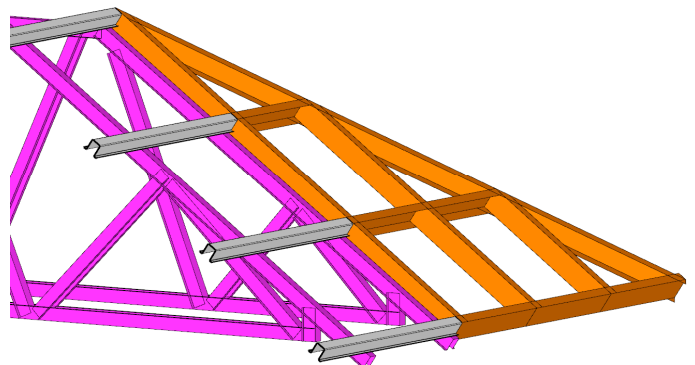



Hybrid Gable Installation

Gable Hybrids begin in the same manner as a Hip Hybrid, with the ceiling frame being the first component to be installed.

Once laid on top of the wall frames, the ceiling panel should be screwed with one screw at each end. Through the ceiling into the gable wall studs.

The ceiling panel should be checked for square and adjusted to suit. If strap bracing is required, it should be installed and tensioned now.

Once squared the walls should be made flush with the ceiling panel and screwed at each corner. If more than one ceiling panel is required, it may need to be propped in the middle until the truss is installed.

Next, check the height of the centre of the ceiling against the gable wall. Once it is confirmed to be straight and not sagging, it should be screwed off with 1/10g-16x16 Tek screws at approx 600mm centres.

Then install the first truss against the ceiling panel.

Note: Lips at the cut ends of the truss bottom chord may be slightly flared due to the cutting action of the Rollformer. Bend these lips inwards to form the correct profile shape at the ends of the truss.

Check the height of the ceiling chord against the bottom of the truss then screw off with 45mm screws at approx 600mm centres.

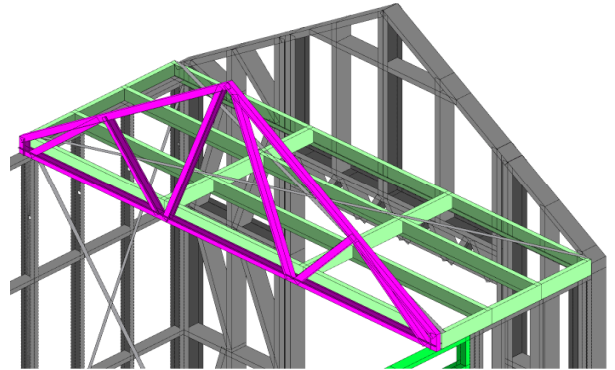

Place any support frames on top of the ceiling and screw the bottom in the correct location. Do not fix the top until the roof panels are in place.

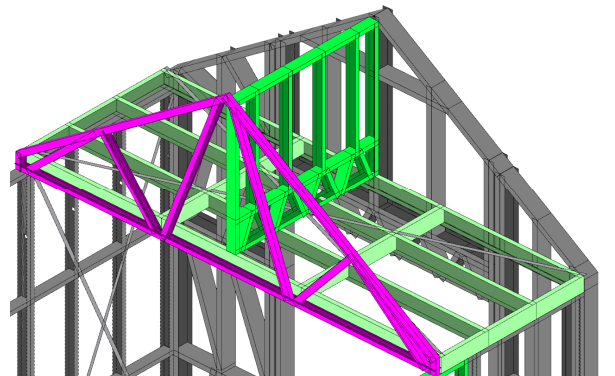

Install roof panels next ensuring that all overhangs are correct and the roof panel is square. Ensure the roof panel is screwed to the truss at the correct height above the top of the truss to allow the purlin or batten to join seamlessly across the top.

Apply fixing through the roof panel into the support frames then attach roof panel hold downs as per the engineers specifications.

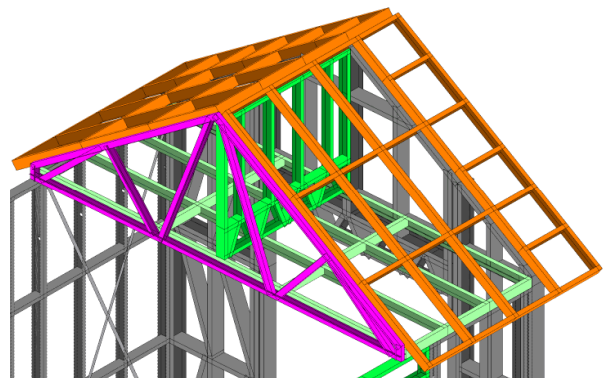



Floor Panels

Floor Panels are formed with a “ceiling panel” that has been engineered to withstand the loads of the building’s floor. Floor Panels are an extremely fast way of forming a floor. It also keeps the thickness of the floor to a minimum. Typical Floor Panel thicknesses are 90mm and 140mm without the flooring material.

Panel floors are typically fixed down in the same manner as a ceiling frame, with a strap or just a tek screw.

Panel floors can also be fixed to the face of a wall frame. When this is the case the hold down connection is formed with the shear strength of the screws used. The screw connection must be confirmed as adequate by the certifying engineer.

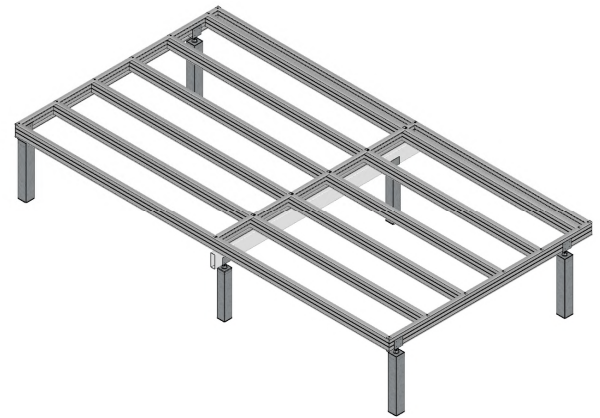

Floors spanning continuously over interior walls or bearers generally do not need additional hold downs (except where wall bracing is above). Typically only fixings to hold the wall or bearer below in place are required. This is to be confirmed by the certifying engineer.

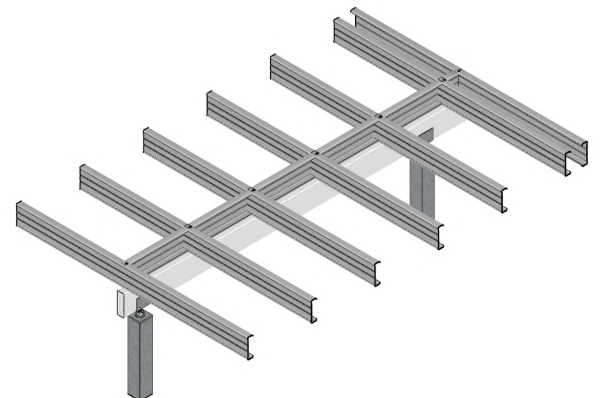

Laying Out Floor Panels

When laying out Floor Panels, first become familiar with the ScotLayout supplied by the manufacturer.

With Floor Panels there are no orientation holes, so they must be orientated by referencing the layout with any special nogs within the frame.

These special nogs can be extremely important later on in the build, so special attention should be paid to them for correct panel orientation.

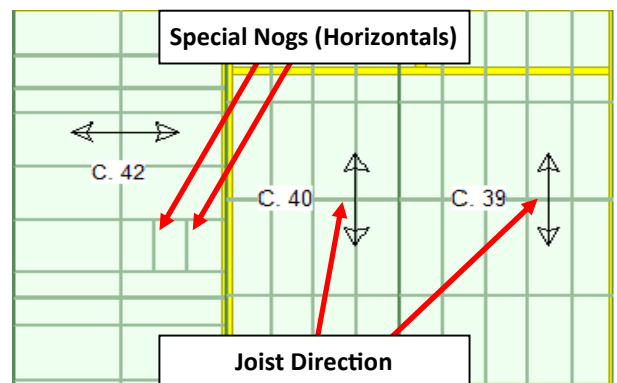



Brackets and Fixings

Outlined in this section are different ways to secure floor joists to framing in many different forms. It also includes ways to form joist to joist connections. Connection capacities must be confirmed by your engineer and must be suitable for the loads they are trying to restrain.

Panel Joist to Wall Connections

When a joist is resting on top of a wall, the connection must be capable of restraining the joist in a vertical direction. Therefore an additional bracket will need to be added to restrain the joist in shear.

Floor Joists can be successfully cantilevered over supporting walls. These connections are similar to standard hold down connections, but these must be confirmed by the certifying engineer.

Panel Joists can be screwed directly through the end web into the supporting stud to fix the joist in place.

Truss Joists can also have this done, however a preferred method is to fix a piece of truss profile to the wall studs first, then slip the truss inside this and screw the joist into place through the bracket.

Floor Joists can be engineered to act as a girder joist and support one or many other joists. Typical girder joists will have vertical members inserted at the point the child joists join. Connections can be made by either screwing directly through the vertical members into the end web of the joist, or by fitting a bent steel bracket to each side of the joist. Custom made boot style brackets could be used for joists with large loads. All connection types must be confirmed by the certifying engineer.

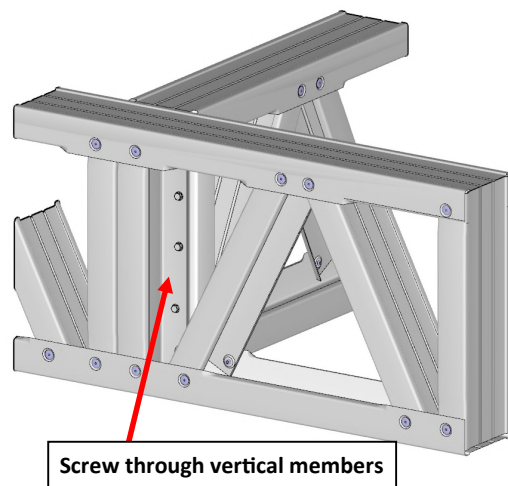
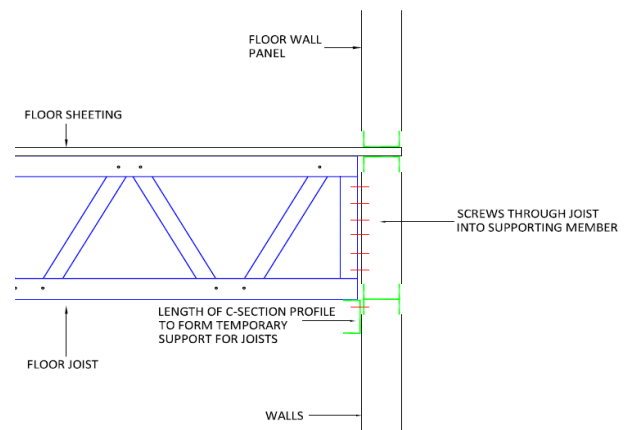
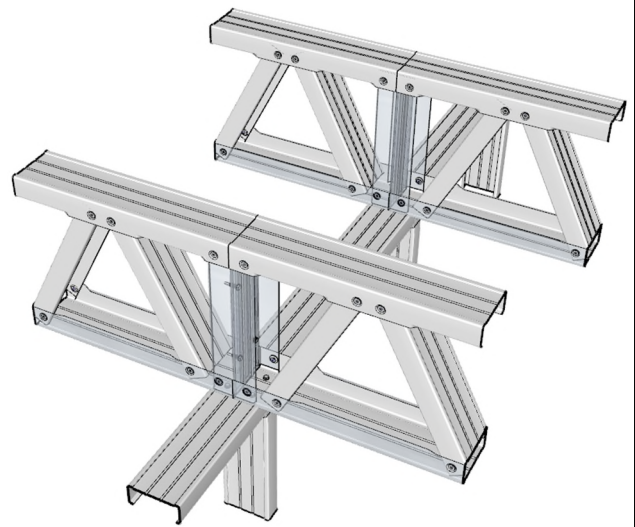



Floor Trusses

Floor Trusses can be treated the same as Floor Joists. The profile is different, therefore the spans are greater and the ways of fixing the joists down can be slightly different. The principle of fixing types are essentially the same as panel joists. Using screws in a shear direction through the steel sides that connect together.

Floor Trusses can be held down using either a pre made bracket or a strap, either wrapped over a chord of the truss or extended up the end vertical member of the truss.

All brackets and straps must have sufficient screws in the shear direction to resist any movement.

Note: Some joists will only require screws to hold them in place with no additional bracket.

Floor Truss to Floor Truss connections are easily made using a short piece of truss profile.

Sufficient screws must be used in both girder and carried trusses to restrain any loads. Connections are to be confirmed by the certifying engineer.

Floor Truss Orientation holes are provided by an additional hole in the bottom chord at the start end only. Although this is on the vertical edge of the chord, it is shown on the Layout the same as a normal orientation hole.

Floor Trusses can be supported by walls using a style called "Tail Bearing". This means the top chord of the Floor Truss is extended over the supporting wall and resting on it. Fixings are then made through the wall stud below to restrain the truss from twisting and moving out of plumb.

Tail bearing trusses should be screwed down through the tail bearing lips into the top plate, and screwed through the wall stud into the end web of the Floor Truss.

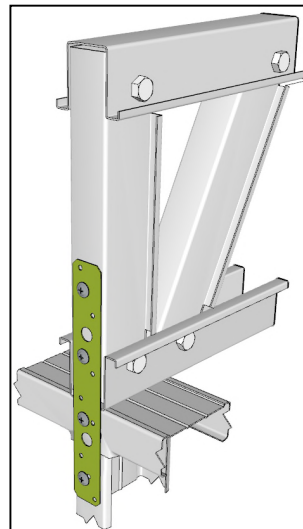

Vertical Strap Hold Down

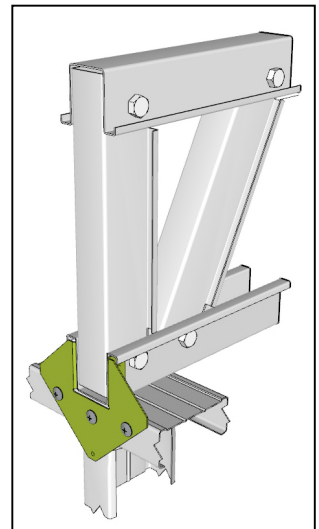

H1A Hold Down

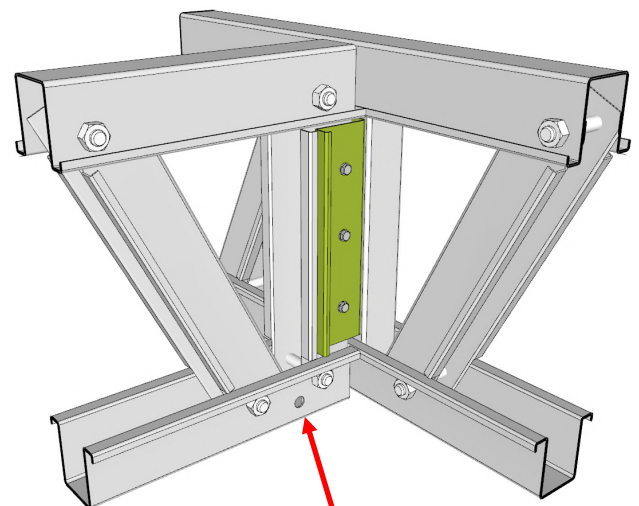

Orientation Hole

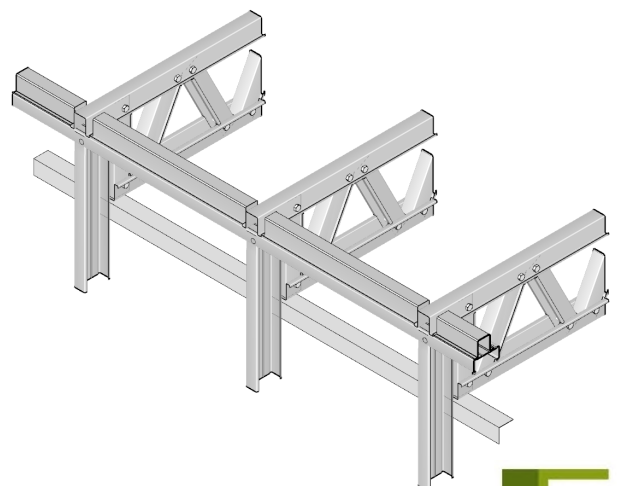



Laying out Joists

Laying out Floor Joists can be done by first becoming familiar with the ScotLayout supplied by the manufacturer.

Floor Joists use an orientation hole in the same way Wall Panels do. A service hole is punched 100mm from one end. This is illustrated on the Layout by a dot near the end of the joist. Joists should be placed in the same orientation as specified in the Layout.

Pre marking the top plate of the supporting walls is recommended to increase the speed of erection.

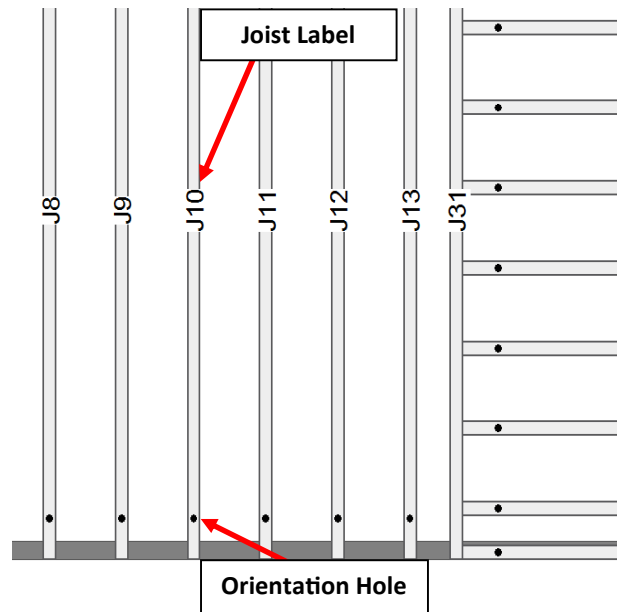

Joist Bracing

Bracing within floors can be achieved by either adding blocking between the joists or floor trusses, or by applying a strap in a herringbone type configuration to resist a raking force.

To apply a Herringbone Strap, connect a strap to either the top or bottom chord of a Joist. Then pass the strap over or under the adjacent joist and repeat until the desired number of joists have a strap over them. Repeat this process beginning on the alternate Joist chord. Once each strap is fixed at each end, ensure the end joists are braced in a rigid position to prevent them being twisted when the straps are tensioned. These joists are now acting as an anchor for the Herringbone Strap. Add a tensioner to each strap and tension until they are taught between each joist.

When the strap is tensioned to a satisfactory tension, ensure each joist is plumb within the strapping. Now fix the strap with a wafer head screw in the centre of each chord web the strap passes over or under.

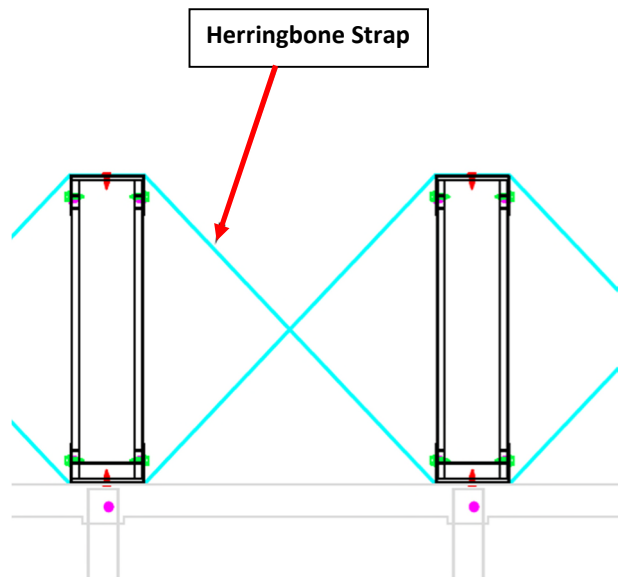

Floor Bracing can be achieved by forming blocking between strategic joists. This is done by installing small frames with a diagonal brace.

This blocking type is typically used over supporting walls. The herringbone type is used at mid-span of joists.

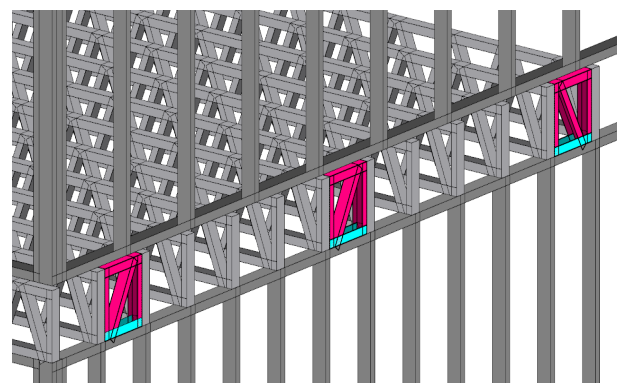



Flooring Material

Sheet flooring should have glue laid along the steel joists immediately before fitting the flooring. Flooring should then be screwed down using Wing Tek screws. It is best to place larger amounts of glue in the areas away from rivet connections in the floor panels, then hold the flooring down by screwing into the loadbearing joist members. When working with a floor panel, screws should be close to the rivet connection. This helps prevent an uneven floor surface.

Flooring material placed over steel joists should be evenly glued prior to fitting the flooring and then screwed evenly along each joist until it is held down firmly.

Joins between sheets should have glue applied to each edge prior to joining to prevent flooring movement at sheet joins and creating movement squeaks between flooring sheets.

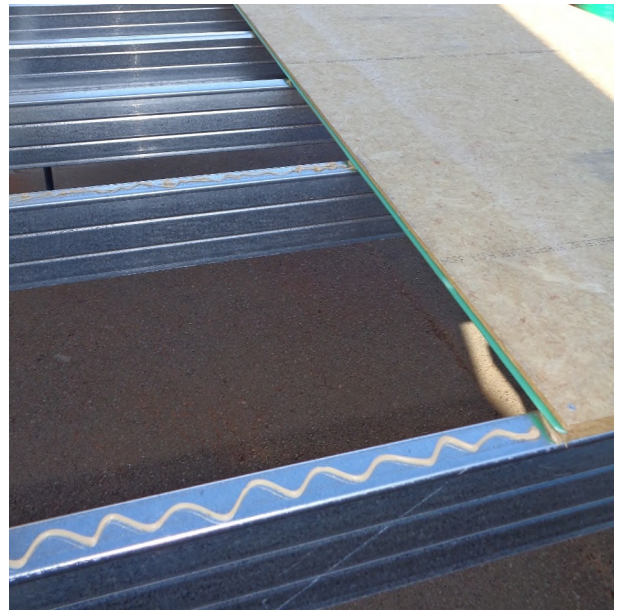

Flooring sheets should be staggered when being laid out. This provides maximum strength for the floor diaphragm and the flooring system.

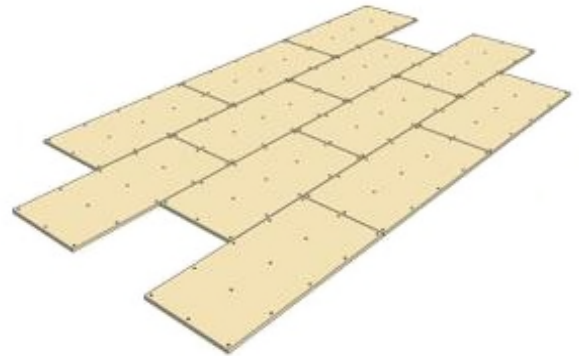

Flooring material should be screwed down with Wing Tek screws and glued at all edges. Screw spacing's should be based upon floor joist engineering requirements and flooring manufacturers specifications.





Notes



Removing Rivets

To drill out a miss fired rivet you will need a 4.9mm double ended drill bit and battery drill as listed in Chapter 1. Place the drill bit in the centre of the rivet on a slight angle to prevent rivet rotation. Once the drill bit starts to remove the head, the bit can be positioned vertically to complete the process. In some cases the body of the rivet will remain in the hole so you may need to keep drilling until the rivet body has been totally removed.



To begin use a C clamp to prevent the bottom flange bending while pressure is applied from the drill bit.

Once the rivet has been removed a new rivet can be reinserted to replace the miss aligned rivet. Special attention needs to be given as to which rivet to use which is covered below.



Rivet Type

The ScotPanel system uses an Open Type Blind Dome Head rivet. Referred to as a SS6-2 or SS6-3 rivet (SS refers to Steel Body/Steel Stem)

Diameter	Code	Grip Range	Shear (min)	Tensile (min)
4.8mm	SS6-2	0.5—3.2	2400N	3030N
4.8mm	SS6-3	3.2—4.8	2400N	3030N

It is suggested using SS6-2 for 0.55 to 0.75mm BMT gauge steel and SS6-3 for 0.95 to 1.15mm BMT.

Its important that the correct grip range is used so all steel layers are pulled tightly together.

Note: Aluminium rivets are NOT to be used.

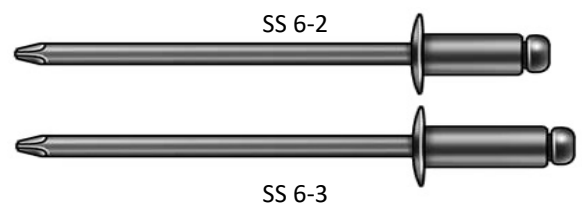



Services Through Bottom Plate

When removing a section of the bottom plate to allow services to be hidden in the walls, first make sure the correct wall has been selected. Lie the wall on the ground in the exact position with the correct orientation.

Mark the outline of where the cut to the frame needs to be. Using the snips, remove the section of the bottom plate as per the example in the adjacent image.

With the section of the bottom plate removed, stand the frame up and slide the frame into the correct position. Fix the two end studs where they meet the connecting walls and straighten the bottom plate. When satisfied everything is correct, pin each end of the bottom plate where the cut was made with concrete nails.

In the adjacent image the bottom plate has had a section completely removed to allow for services, the same procedures as above should be followed.

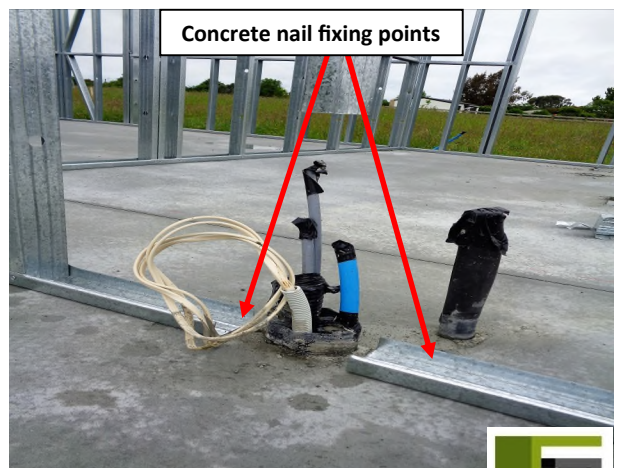
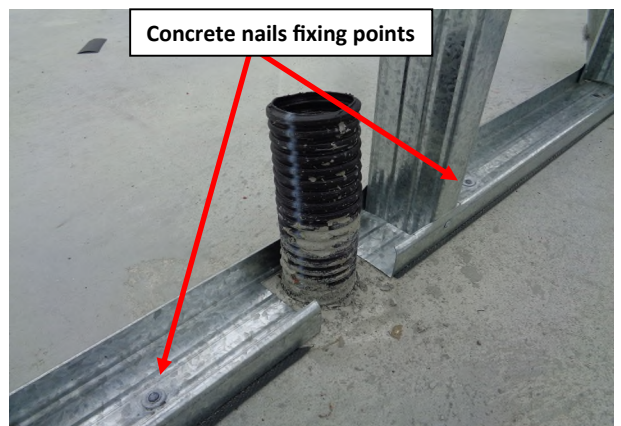
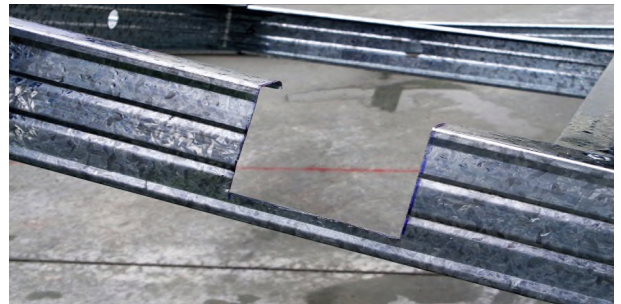



Moving K Brace for the Fixing Bracket

At times the wall tie down bracket installation is impeded with the K bracing.
To get fixing on the tie down bracket, the K brace will have to be moved.

Remove the rivets at the end of the nog as well as the K brace that goes into the bottom plate.

With the rivets removed, lift up the end of the nog that the rivets have been removed from, which will move the K brace out of the bottom tray. Tek screw the bracket into the stud and fix to the floor (slab). Slip the K brace back into place followed by the nog then replace the removed rivets.

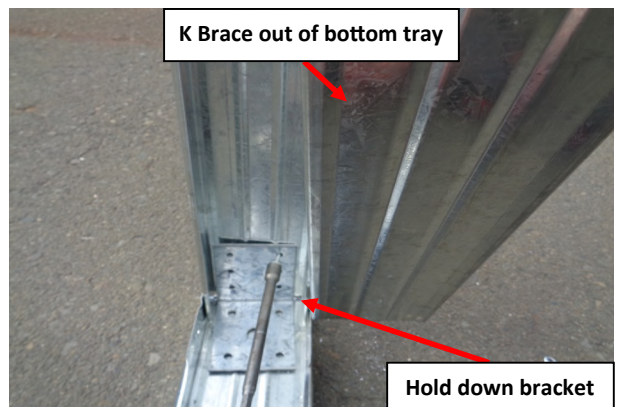
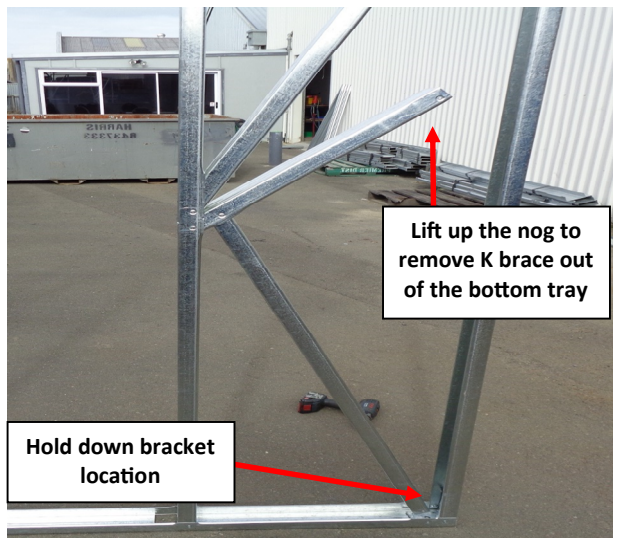



At times extra service holes are needed to be added to panels for wiring or plumbing.

In the adjacent image you will see a cone drill bit (step drill) with hole diameter measurements. Find the 28mm diameter and drill to the correct depth being careful not to plunge deeper as this will cause the electrical grommet (snap-in bushing) to fall out.

To find out the hole size, measure the orientation hole.

Most common hole punches on Scottsdale roll formers are 28mm, there are some roll formers that are 25mm.

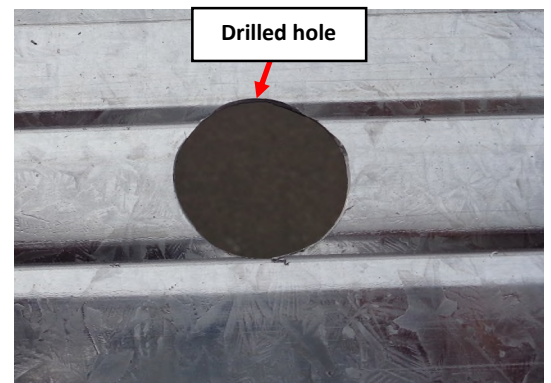

After the hole has been drilled, a 28mm electrical grommet needs to be inserted to prevent chafing of electrical cable or contact with dissimilar metals around services. Grommets can be sourced at most electrical outlet stores or contact Scottsdale Construction Systems.





Layout for Walls

Walls are represented on a layout in the location and orientation they were drawn in the design software. These layouts are easily interpreted with a small amount of knowledge of a layout.

Depending on the size of the project will depend on the number of pages contained within the layout.

Generally the first few pages will be dedicated to walls. Some layouts may have more than just walls on each page .

Some layouts will have information about walls on pages containing only the following, Exterior Dimensions, Interior Dimensions, Panel Labels, and Openings.

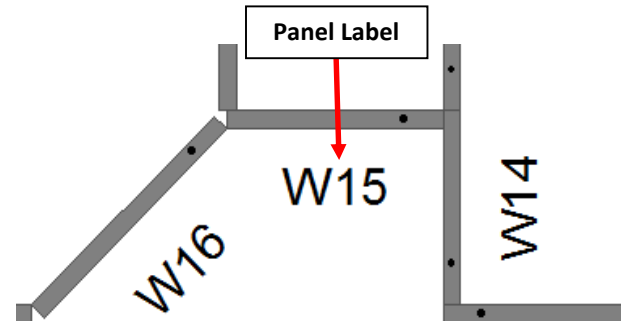

Each Wall Frame will have a label. This is generally orientated in the same direction as the wall panel ie vertical or horizontal.

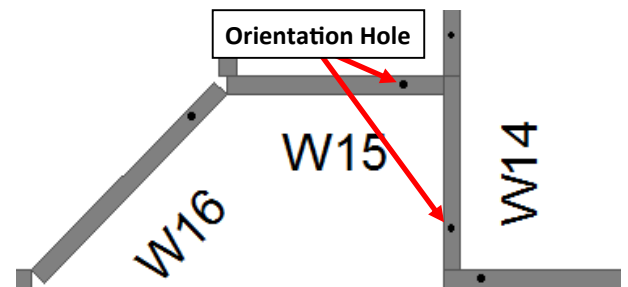

Each Wall Frame will have an orientation hole punched in the bottom plate approximately 100mm away from the end of the frame. This is represented on the layout by a black dot.

Note: The orientation hole will always be shown the same distance from the end of the frame, regardless of the length of the frame. This means if the frame is 150mm long the orientation hole will be both punched and illustrated closer to the end of the frame rather than the start of the frame.





Walls will be dimensioned with simple architectural style dimensioning.

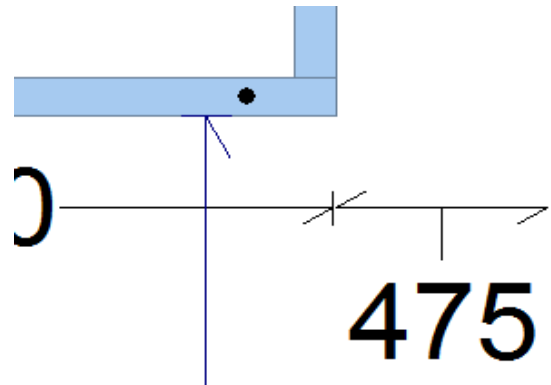

Some Layouts will contain detailed information about the framing, such as the height of individual wall frames, the steel gauge, and the vertical member spacing.

Walls (Level 1)				
Wall	Height	Gauge	Hor. Spread	Vert. Spread
W1	2810	C90_37-0.75BMT-G550	1200	600
W2	2720	C90_37-0.75BMT-G550	1200	600
W3	2810	C90_37-0.75BMT-G550	1200	600

Supports

Supports are illustrated in the same way as walls, with an orientation hole at one end and a label positioned next to the frame in the same orientation as the frame.

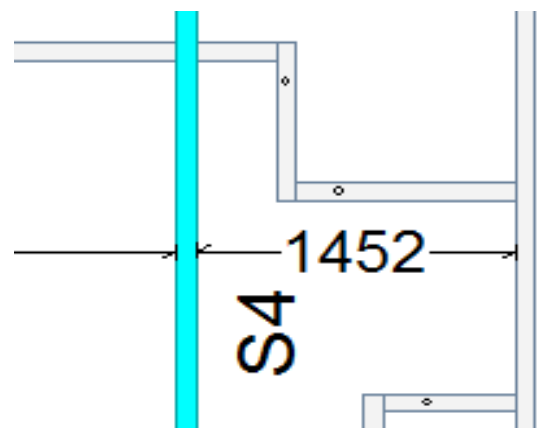

Some Layouts will contain detailed information about the support frames, such as the height above the floor, and the steel gauge.

Supports (Level 2)		
Support	Height	Gauge
All Supports (Level 2)	2720	C90_37-0.75BMT-G550





Openings

A ScotLayout will often have the opening sizes listed on the layout for builders and installation teams to check.

Windows and Doors are illustrated with two slightly different symbols.

Opening sizes can also be placed on the Layout. They can be illustrated in one of three ways with a label orientated in the same direction as the wall the opening is in.

The opening label can also show the bottom chord height of the lintel.

The openings can be given a label and the sizes listed in a table divided into windows and doors.

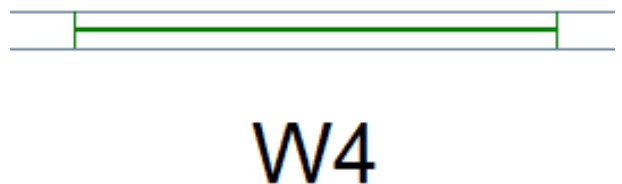
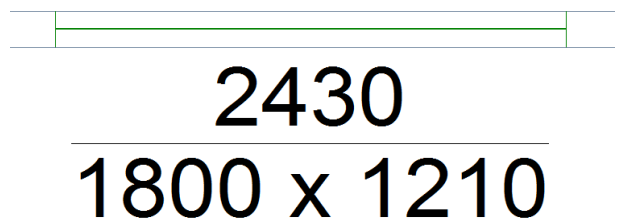
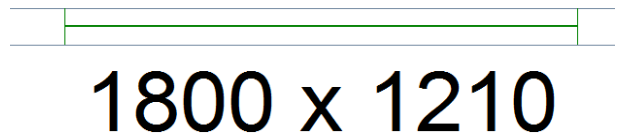
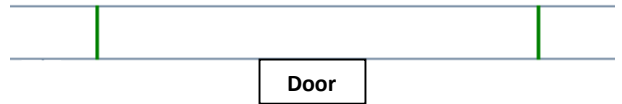

Windows (Level 1)				
Label	Width	Height	Top	Count
W1	850	1200	2150	1
W2	850	600	1550	1
W3	2170	1800	2300	1
W4	1210	1800	2430	1
W5	2410	1800	2430	1
W6	2410	850	2100	1
W7	610	600	2300	1
W8	4070	600	1550	1

Doors (Level 1)			
Label	Width	Height	Count
D1	1200	2300	1
D2	4810	2200	1
D3	3010	2100	1
D4	820	2100	3
D5	1640	2100	2
D6	1000	2100	1
D7	1440	2100	2
D8	3000	2100	1
D9	900	2100	1
D10	720	2100	2
D11	1500	2100	1





Floor Joists

Floor Joists are illustrated similar to a wall frame, with an orientation hole at one end and a label orientated in the same direction as the joist.



Ceilings

Special attention should be paid to ceiling panels when placing them on the walls as there is often extra nogs added to the frame to satisfy fixing requirements for later on in the build.

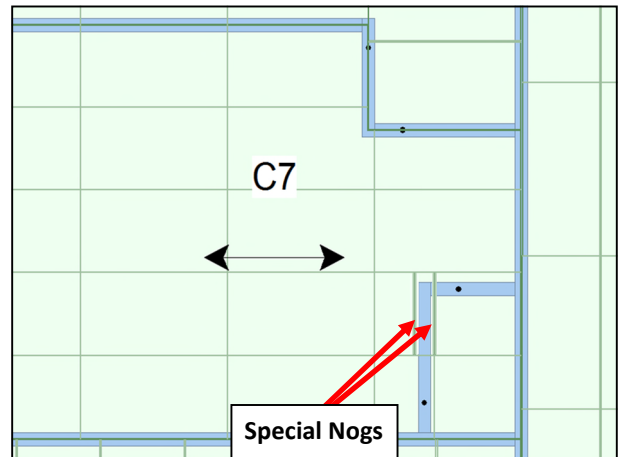

Ceiling pages can sometimes have additional details added with information about the frame, such as the steel gauge used, the joist (vertical member) spacing, and the nog (horizontal member) spacing.

Ceilings (Level 2)				
Name	Steel	Horz. Spacing	Vert. Spacing	
C7	C90_37-0.75BMT-G550	1200	600	
C8	C90_37-0.55BMT-G550	1200	600	
C9	C90_37-0.55BMT-G550	1200	400	

Roof Panels

Roof Panels are illustrated essentially the same as the Ceilings with the label and the rafter direction given in the middle of the panel. Once again, special attention should be given to any special members to ensure the panel orientation is correct in the building. Dimensions of Roof Panels are measured on the bottom face of the panel.

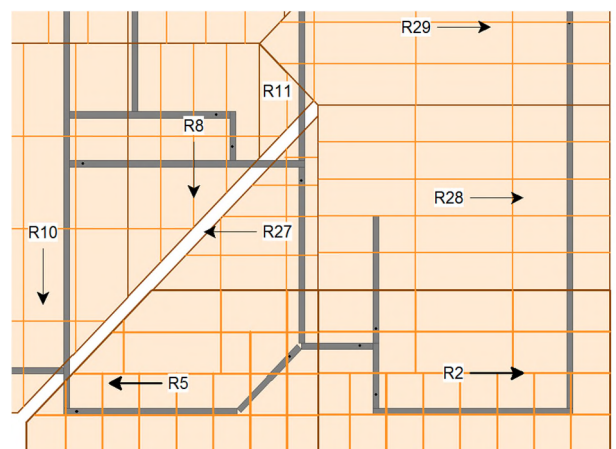



Roof and Floor Trusses

Roof and Floor Trusses are usually given their own page for clarity to the layout.

Roof Trusses have a label that is automatically placed at one end of the truss along with the dimension to the nearest truss. This dimension is shown from centre to centre.

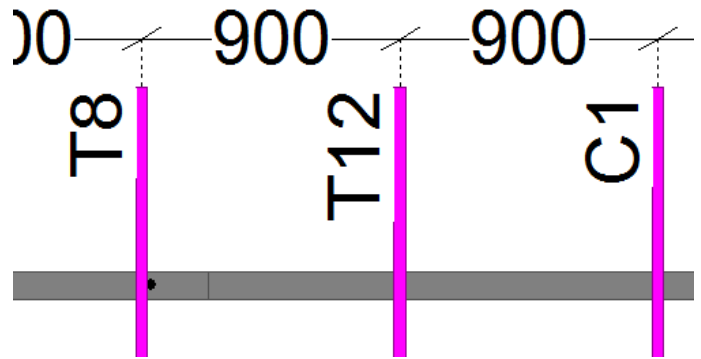

Floor Trusses have a label that is automatically placed at one end of the truss along with the dimension to the nearest truss. This dimension is shown from centre to centre.

Floor and Roof Trusses have no indication from the rollformer or from the Layout to indicate the orientation. It is the responsibility of the installer to ensure that the truss is installed the correct way.

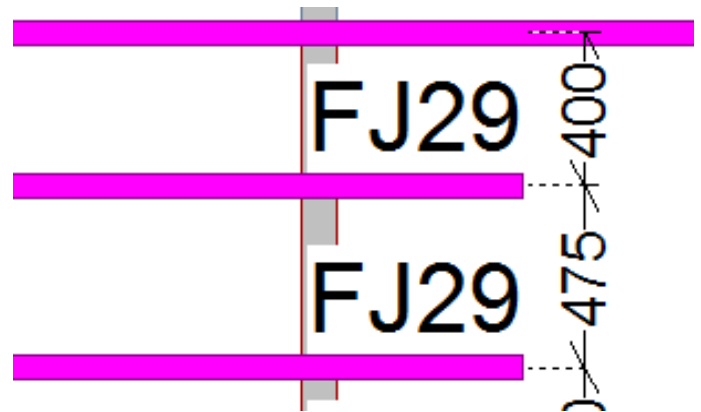

When installing Roof and Floor Trusses, there must always be a web positioned within the truss above the load bearing point or points of the truss.

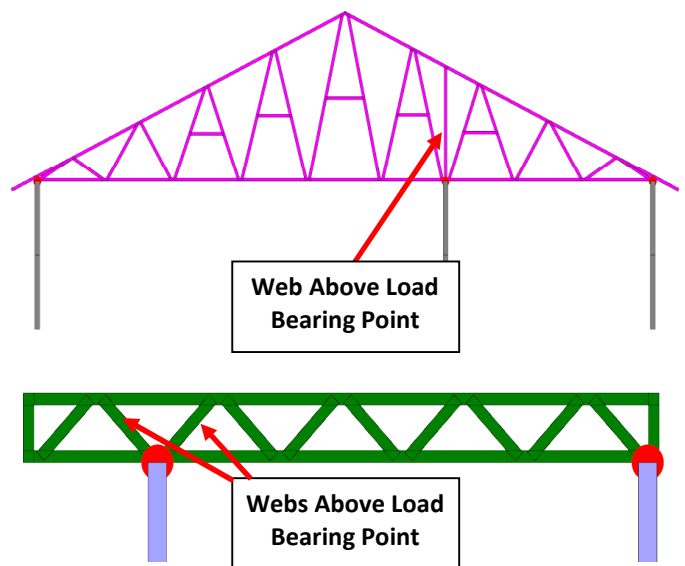



Notes





A

Anchor Bolts Bolts set in concrete, used to anchor structural members to concrete foundation.

B

Back to Back Two "C" section steel items with the back of the webs touching and flanges pointing away from each other. Should be screwed together to get maximum benefit

Batten Length of material screwed to the structure to provide a fixing surface for roofing or ceiling material

Beam A length of sturdy squared material used to support the roof or floor of a building

Beam Pocket A space provided within a frame or truss for a beam to rest on and be fixed to

Bottom Chord The lowest longitudinal member of a truss or lintel. It's usually horizontal, but may be at an incline depending on the truss or lintel design

Bottom Plate Refers to the bottom most horizontal member of a panel frame

Bracing Straps or sheeting applied to the face of framing or a roof, to help maintain a rigid square profile

Bracket A structural support projecting from a wall or column on which another structural member is fastened

Buckling Bending in an abnormal direction

Building Code Regulations established by a recognised agency describing design loads, procedures and construction details for structures. Usually apply to designated geographical areas

Building Wrap Breather type underlay fabric which allows water vapour to pass through from one direction

C

"C" Section A member cold-formed from steel coil in the shape of a "C"

Cantilever Projection of a building or member beyond its support

Cladding The external envelope of the building, particularly of the walls

Code Local authority or national building regulations or requirements

Concentrated Load Super imposed load centred at a given point

Concrete Plastic mixture of aggregates, cement and water which will set to a given mould

Corner Jack A single sloping girder truss at a 45° to its supporting truss. Used to form a ridge in a hip end

D

Dead Load Any permanent load such as the weight of the truss itself, purlins, sheathing, roofing, ceiling, etc

Deflection The amount a member bends or flexes under an applied load

Diaphragm A large flat area braced to provide resistance from any direction

DPC **Damp-Proof Course** is a continuous layer of impervious material placed under the bottom plate to protect the upward migration of moisture. If using Zincolume steel do not use a DPC that has a carbon content

Drawings **Layout** - layout of the site showing the position of the building and the positions of the services.

Details - larger-scale details to show exactly what is required at a certain position.

Plan - layout of the rooms showing all floor areas, windows, doors fixtures, fittings and services

Dutch Gable A roof with a small gable at the top of a hip end

E

Eaves Refer to Soffit

Erection The on-site assembly of pre-engineered components to form complete structure

Engineering Calculations done by an Engineer to determine structural requirements





F

Fascia	Exterior timber/steel trim at the lower edge of a roof to which the spouting or gutter is attached
Flange	The sides of a "C" section, perpendicular to the Web
Flashing	Waterproof material installed to prevent the passage of water into a structure at a cladding joint
Foundations	Base of the building that rests on the ground and supports the structure
Framed Opening	Opening in a wall that is framed with light gauge members
Framing	Steel items that have been riveted together to form a panel frame. Frames make up the structural skeleton of a building

G

Gable	The triangular upper part of a wall at the end of a ridged roof
Galvanised	Steel coated with zinc to prevent the steel from rusting
Girder	A main horizontal structural member that supports vertical loads from other members
Girder Truss	A truss designed to carry heavy loads from other structural members framing into it.
Grommet	A plastic ring inserted into a service hole to prevent chafing against the sharp steel edge
Gutter	A tray used for carrying rain water to a roof drain

H

Heel Joint	The point on the truss where the top and bottom chords intersect
Hip Roof	A type of roof where all sides slope downwards to the walls
Hold Down	Also known as anchor bolts. These can be: Expansion Bolt and washer Expansion Bolt and "L" bracket Brackets Straps
Hybrid	Two Scottsdale systems used together to make construction faster and easier

I

Insulation	Material used to prevent heat, cold, fire, or sound from passing through the framing
-------------------	--------------------------------------------------------------------------------------

J

Jack Stud	Term used to indicate that a stud member is less than full length.
Jack Truss	A small truss that slopes in one direction only and are supported by another truss at at least one end
Jamb Stud	The vertical stud forming an opening
Joists	Regularly spaced framing members of a floor.

K

"K" Brace	Bracing within the framing using diagonal members forming a "K" Shape
------------------	-----------------------------------------------------------------------

L

Lintel	Structural member above a door or window opening
Live Load	Any moving or variable load which the structure must support
Lips	The small bent edges of the a steel profile
Load Bearing Wall	Exterior walls and any interior walls that are designed to take load from above





N

Nogs Short horizontal items between studs. Also known as Dwangs or Blocking

O

Orientation Hole A hole punched in the bottom plate of a wall frame to indicate the direction it is to be installed

Outrigger A member fixed to a truss to form an overhang beyond the wall line

Overhang The extension of the top chord of a truss beyond the outside of the heel

P

Pile Foundation post below the flooring level

Pitch Slope of a roof plane, usually expressed in degrees eg: 22 degree pitch

Plate A wide strip of steel material

Plating Attaching metal plate to one or two sides of a support frame, floor joist, or lintel to provide extra strength

Plumb Upright, vertical

Point Load A point load is a load applied to a single, specific point on a structural member as opposed to being evenly distributed

Purlin Regularly spaced horizontal roof member set out on top of a steel roof to accommodate the roofing material prior to fixing

R

Rafters The steel items spanning between support points carrying the roof loads

Raking An item that is not horizontal or vertical

Ridge The apex of the roof

Rivet A small headed pin with expandable shank for joining light gauge steel

S

Saddle Truss Used to create a secondary roof line, placed on top of other trusses

ScotLayout Software used to create site drawings and layout information of steel framing

ScotSteel Software used to design Scottsdale Steel framing for manufacturing and construction

Screw Off Placing screws in their required locations to fix items together securely

Service Hole A hole punched in the centre of the web to allow wires and pipes to pass through

Shears An electric or hand tool used to cut steel, also known as Snips

Shear Force Force acting on material in a direction perpendicular to the extension (fixing)

Shim A piece of steel or plastic used to level framing to the slab or flooring

Shoot Wall This is a wall that extends upward past the normal wall height to meet a ceiling or roof plane

Sill The lower horizontal portion of a window or door opening

Skillion Roof A roof sloping on one direction only, without a ridge or peak

Slab A flat concrete floor that the framing rests on

Soffit The undersides of the roof overhang which are horizontal, and often have a gutter attached at the outer edge. Sometimes called Eaves

Span The distance between 2 supporting points

Spreader Bar A beam used with a crane for lifting evenly from two or more points

Square When an internal corner equals 90°

Strap A narrow strip of steel used to fix one item to another to resist Shear Force

Strap Bracing Lengths of Strap attached to the face of wall, roof, or ceiling panels in a crossed orientation to make the framing rigid

Stud Vertical item extending continuously from bottom to the top of a wall panel





T

Top Chord	Inclined or horizontal upper member of a truss or lintel
Top Hat Profile	The shape of the truss profile. Called "Top Hat" as it looks like a traditional top hat
Top Plate	Refers to the top horizontal or raking member of a wall panel
Truncated Girder	A girder truss with a horizontal portion across the top allowing for other members to pass over perpendicular to it
Truss	Shorter framing members assembled into many triangles to form a rigid shape to span between supports. Usually used to form a roof or a suspended floor

U

Uniform Load	Loads that are equal along the entire length of a member
Uplift	Wind load on a building which causes a load in an upward direction

V

Valley	The "V" created where two sloping roofs meet
Vapour Barrier	Sheet material which inhibits the passage of water vapour into the building

W

Web	The widest part of the "C" section that joins the two sides together. This has the small ribs in it
Web Member	Members that join the top and bottom chords to form the triangular patterns typical of trusses and lintels.

Y

Yield Strength	The strength of steel. Usually G550 or G350
-----------------------	---------------------------------------------



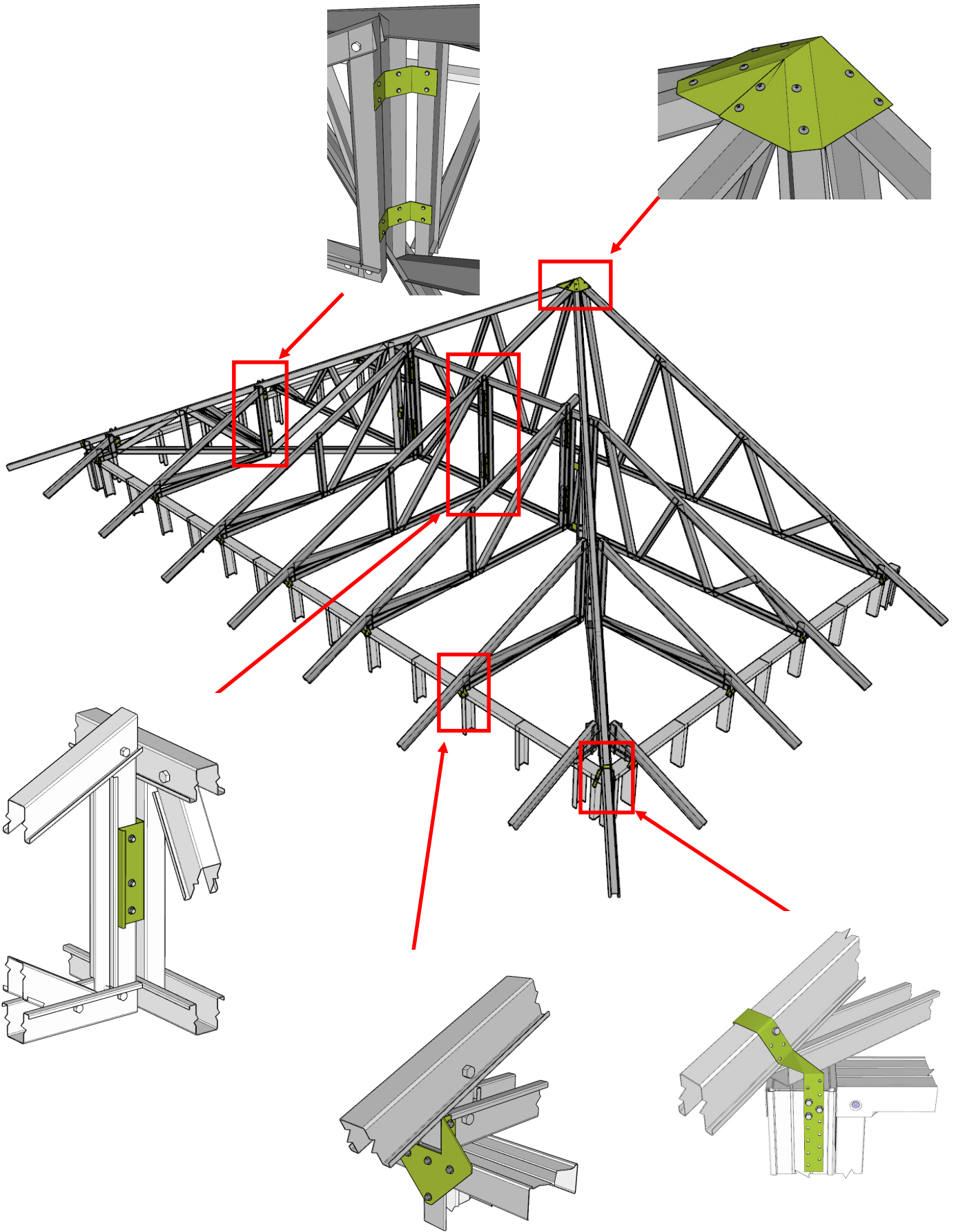

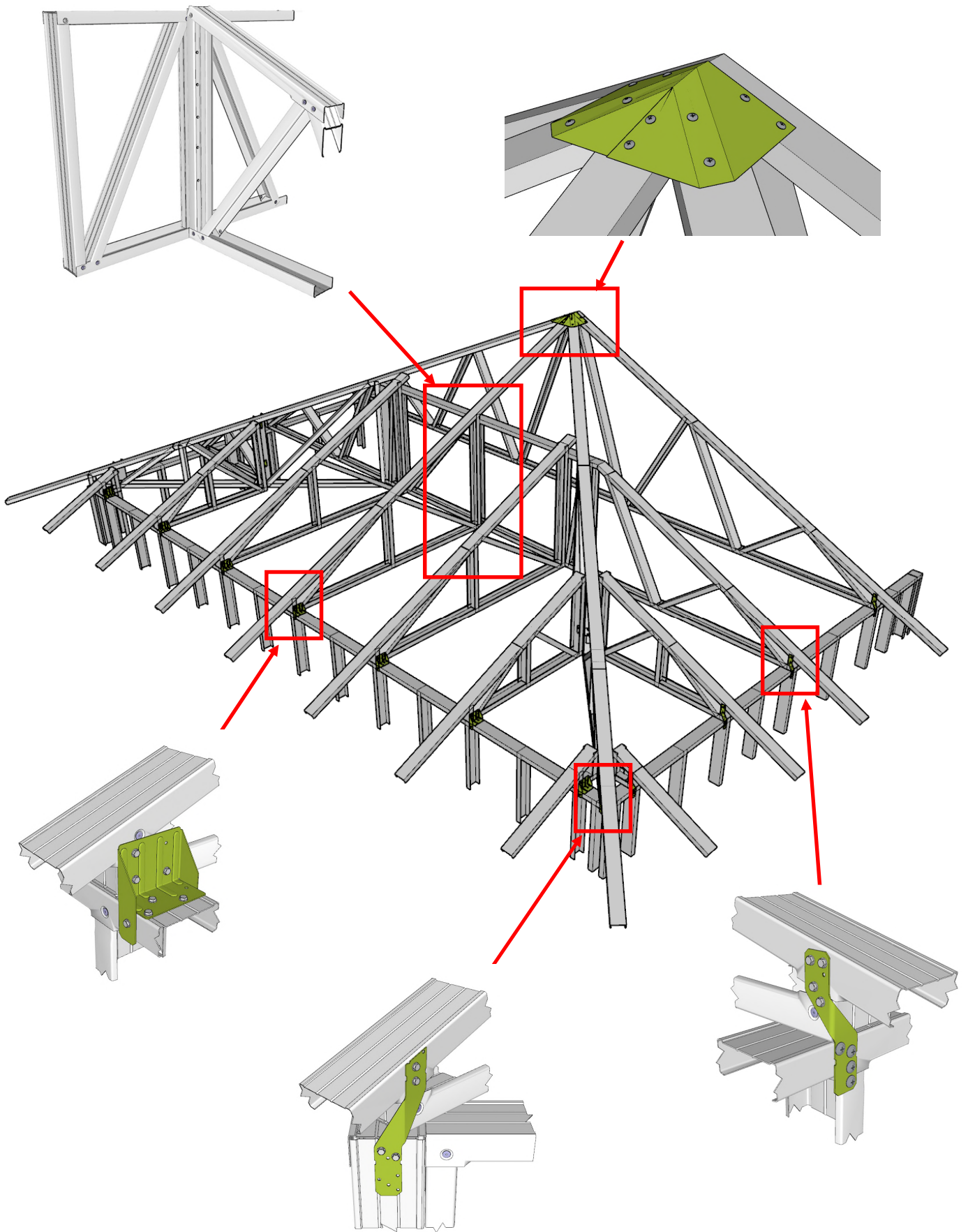

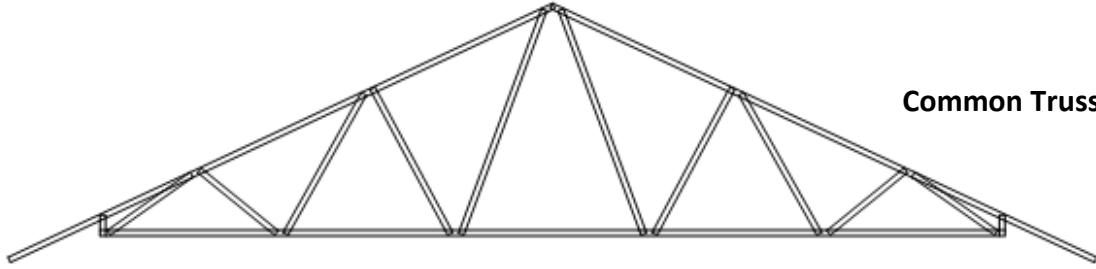

Common Truss

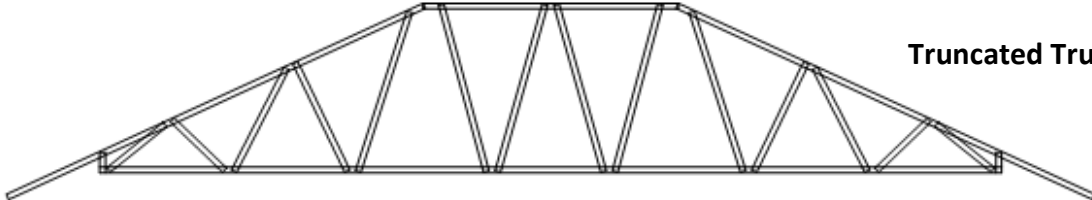

Truncated Truss

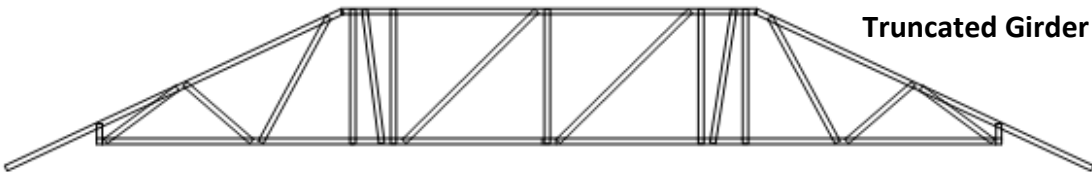

Truncated Girder Truss

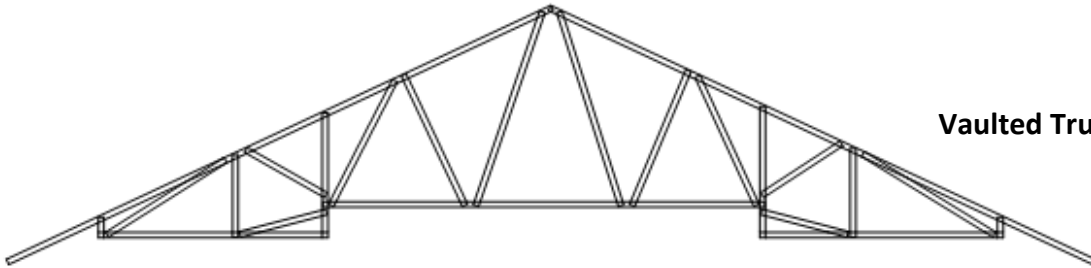

Vaulted Truss

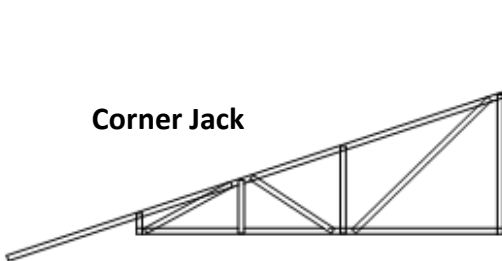

Corner Jack

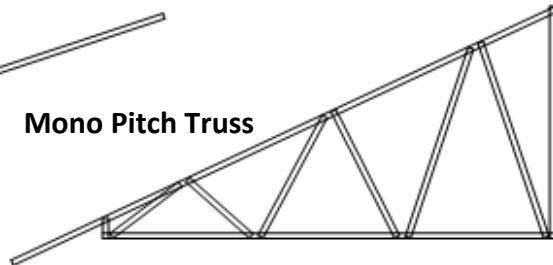

Mono Pitch Truss

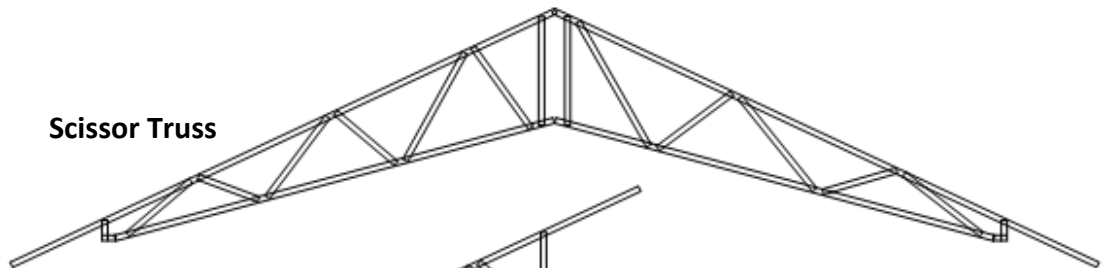

Scissor Truss

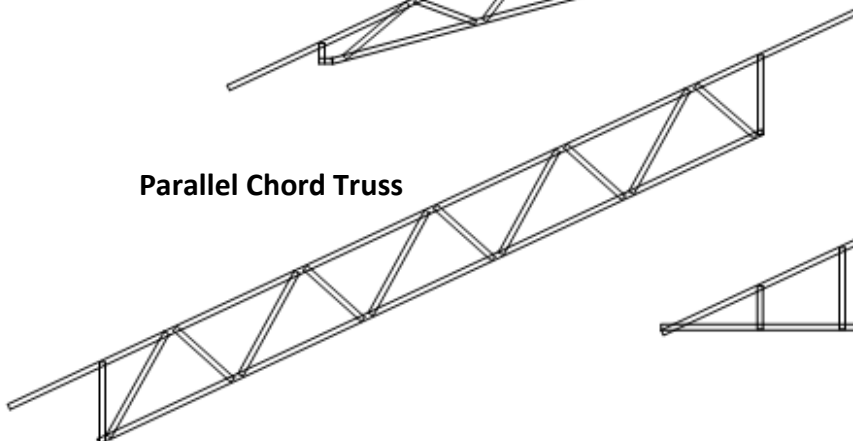

Parallel Chord Truss

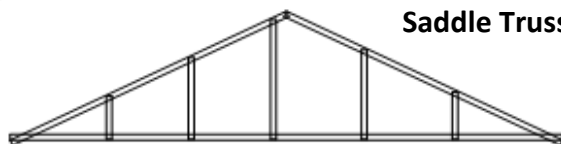

Saddle Truss





Notes

